



# Electric Container Dumper

OPERATION, SERVICE, AND INSTALLATION  
ISSUED JULY 2021

CUSTOMER NAME: \_\_\_\_\_

SERIAL NUMBER: \_\_\_\_\_

**COMPACTION & RECYCLING SOLUTIONS**

**0084-ECD-0721**

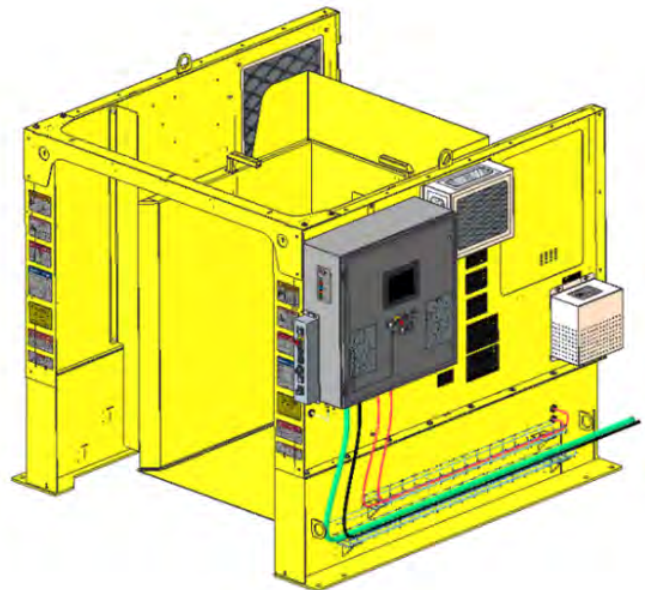
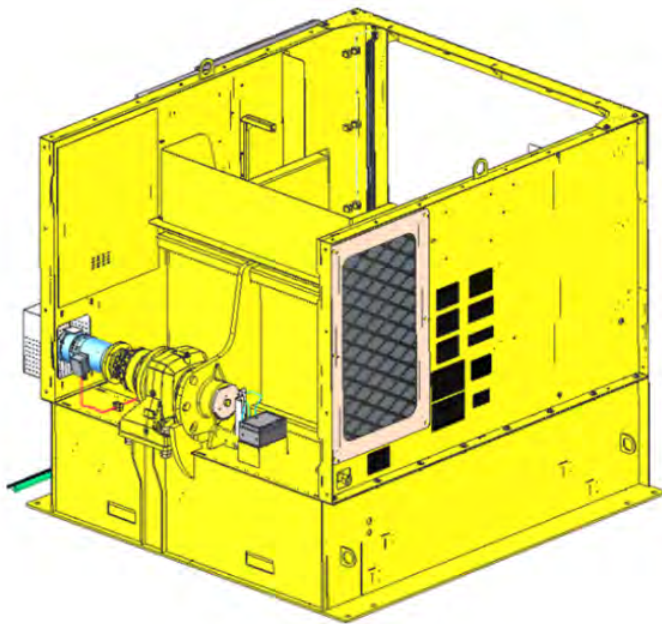

© 2021 Marathon Equipment Company



Environmental Solutions Group  
2030 Hamilton Place Blvd., Suite 200  
Chattanooga, TN 37421  
Marathon Customer Care: 1.800.633.8974



# WARNING

**IF INCORRECTLY USED, THIS EQUIPMENT CAN CAUSE SEVERE INJURY. THOSE WHO USE AND MAINTAIN THE EQUIPMENT SHOULD BE TRAINED IN ITS PROPER USE, WARNED OF ITS DANGERS, AND SHOULD READ AND FULLY UNDERSTAND THIS ENTIRE MANUAL BEFORE ATTEMPTING TO SET UP, OPERATE, ADJUST OR SERVICE THE EQUIPMENT. KEEP THIS MANUAL FOR FUTURE REFERENCE**

## IMPORTANT SAFETY NOTICE

Proper service and repair are important to the safe, reliable operation of the Marathon Equipment Company products. Service procedures recommended by Marathon Equipment Company are described in this Operation, Service, and Installation Manual and are effective for performing service operations. Some of these service operations may require the use of tools or blocking devices specially designed for the purpose. Special tools should be used when and as recommended. It is important to note that some warnings against the use of specific methods that can damage the product or render it unsafe are stated in the service manual. It is also important to understand these warnings are not exhaustive. Marathon Equipment Company could not possibly know, evaluate and advise the service trade of all conceivable ways in which service might be done or of the possible hazardous consequences of each method. Consequently, Marathon Equipment Company has not undertaken any such broad evaluations. Accordingly, anyone who uses service procedures or tools which are not recommended by Marathon Equipment Company must first satisfy himself thoroughly that neither his safety nor the product safety will be jeopardized by the method he selects.

# Electric Container Dumper

## TABLE OF CONTENTS

### General Information

Introduction .....	4
Preface .....	5
Hazard Symbols and Definitions .....	5
Lock-Out/Tag-Out Instructions .....	6
Components .....	8
Service/Parts Assistance .....	12
Guards and Access Covers .....	12
Grease Lubrication Recommendation .....	12
Recommended Gearbox Oils .....	12
Warning Decals on the Unit .....	13
Decal Care .....	13
Electrical Symbols .....	15

### Installation

Contact Information .....	18
Concrete Pad Requirements .....	19
Electrical Installation .....	20

### Operation

Contact Information .....	24
Pre-Operation Instructions .....	25
Control Panel for Dumpers .....	26
Control Panel for Dumpers with Auto-Cycle Function .....	27
Touch Screen Control .....	28
Operating Instructions .....	32
Automatic Operation Troubleshooting Guide .....	34

### Service

Contact Information .....	50
Lock-Out/Tag-Out Instructions .....	51
Periodic Maintenance .....	53
Brake Motor Operation .....	55
Maintenance/Housekeeping Stop .....	58
Principles of Operation .....	59
Fuse, Circuit Breaker, & Wire Size Charts .....	60
Electrical Schematics .....	61
Electrical Schematics Stand Alone Dumper .....	66

### Replacement Parts

Contact Information .....	70
Replacement Parts List .....	71
Decal Placement .....	76
Decal Images .....	78
Decal Images (Continued) .....	81
Decal Images (Continued) .....	82
Decal Images (Continued) .....	83

<b>Index</b> .....	<b>85</b>
--------------------	-----------

# **Electric Container Dumper**

**INTENTIONALLY LEFT BLANK**

# Electric Container Dumper

**OPERATION, SERVICE, AND INSTALLATION**

**ISSUED JULY 2021**

**0084-ECD-0721**

**INTENTIONALLY LEFT BLANK**

# **SECTION 1**

# **GENERAL INFORMATION**

# Electric Container Dumper

## General Information

### INTRODUCTION

Thank you for purchasing a Marathon® Electric Container Dumper!

This product is designed to give you reliable service and superior performance for years to come. The purpose of this manual is to provide the owner and/or operators with the necessary information to properly install, operate, and maintain the machine. Also included are sections regarding troubleshooting and service procedures. The manual is not intended as a primary training source, but as a reference guide for authorized, trained personnel. Each person involved in the operation, maintenance, and installation of the machine should read and thoroughly understand the instructions in this manual and follow ALL warnings.

Employers involved in the operation, maintenance, and installation of the machine should also read and understand the most current version of the following applicable standards:

#### **ANSI STANDARD NO. Z245.2, "STATIONARY COMPACTORS SAFETY REQUIREMENTS"**

A copy of this standard may be obtained from:

**ENVIRONMENTAL INDUSTRIES ASSOCIATION  
4301 CONNECTICUT AVENUE, NW SUITE 300  
WASHINGTON, D.C. 20008**

#### **OSHA Standards - 29 CFR**

Refer to:

- Part 1910.147: "The Control of Hazardous Energy (Lock-Out/Tag-Out)"
- Part 1910.212: "Machinery and Machine Guarding: General Requirements for all Machines"
- All other applicable OSHA Standards

---

#### **ANY SERVICE OR REPAIRS THAT GO BEYOND THE SCOPE OF THIS MANUAL SHOULD BE PERFORMED BY FACTORY AUTHORIZED PERSONNEL ONLY!**

If you should need further assistance, please contact your distributor. You will need to provide the equipment serial number, installation date, and electrical schematic number to your distributor.

**If you have any safety concerns with the equipment or need further information, please contact us at:**

**Marathon Equipment Company  
P.O. Box 1798  
Vernon, AL 35592-1798  
Attn: Field Service Department  
877-258-1105**



# Electric Container Dumper

## General Information

### PREFACE

The following sections are a guide for maintenance and service of the Marathon Equipment Company unit. The sections cover preventive maintenance, adjustment, and troubleshooting hints. Before performing maintenance, check the work area carefully to find all the hazards present and make sure all necessary safeguards or safety devices are used to protect all persons and equipment involved. In order to diagnose a problem quickly and effectively, a service person must be thoroughly familiar with the machine. This Operation, Service, and Installation Manual explains the system and its major components. Diagrams and schematics of the electrical and hydraulic systems are in the Service Section.



### IMPORTANT!

- Before starting any maintenance, study this section of the manual.
- Read all hazard warnings and decals on the unit.
- Clear the area of other persons before performing any maintenance.
- Know and understand safe use of all controls.
- It is your responsibility to understand and follow manufacturer's instructions on equipment maintenance and care.

### HAZARD SYMBOLS AND DEFINITIONS

Listed below are the definitions for the various levels of hazards. It is important that the operators of this equipment and people who service units read and understand all warnings as they relate to this equipment operation.

- **DANGER** – indicates an imminently hazardous situation, which **WILL** result in **DEATH** or **SERIOUS INJURY** if you don't follow proper instructions.
- **WARNING** – indicates an imminently hazardous situation, which **COULD** result in **DEATH OR SERIOUS INJURY** if you don't follow proper instructions.
- **CAUTION** – indicates an imminently hazardous situation, which will result in **MINOR** to **MODERATE INJURY** if you don't follow proper instructions.
- **NOTICE** – means unit or other property may be damaged if these instructions are not followed.

You must read and obey all warnings in any manual produced by Marathon Equipment Company to support your unit.

# Electric Container Dumper

## General Information

### LOCK-OUT & TAG-OUT INSTRUCTIONS

#### **DANGER**



Before servicing dumper, be sure that all sources of energy have been shut off, all potential hazards have been eliminated, and the dumper is locked-out and tagged-out in accordance with OSHA and ANSI requirements.

The specific Lock-Out and Tag-Out instructions may vary from company to company (i.e. multiple locks may be required, or other machinery may need to be locked-out and tagged-out). The following instructions are provided as minimum guidelines.

### INSTRUCTIONS

1. Notify all affected employees that servicing, or maintenance is required on the dumper and that the dumper must be shut down and locked out to perform the servicing or maintenance.
2. Perform a hazard assessment;
  - a. The authorized employee shall refer to the company procedure to identify the type and magnitude of the energy that the dumper utilizes, shall understand the hazards of the energy, and shall know the methods to control the energy.
3. Wear proper personal protective equipment.
4. If dumper is operating, it must be shut down by the normal stopping procedure.
5. De-activate the energy isolating device(s) so that dumper is isolated from the energy source(s).
  - a. Shut down all power sources.
  - b. Move the main disconnect lever to the OFF position.
6. Lockout the energy isolating device(s) with assigned individual lock(s).
  - a. Padlock the disconnect lever with a keyed padlock and take the key with you.
  - b. Along with the padlock, place an appropriate, highly visible, warning tag on the disconnect lever. The tag should provide a warning such as:
    - “Danger: Do not operate equipment. Person working on equipment.” or
    - “Warning: Do not energize without the permission of \_\_\_\_\_.”
  - c. Place forks/tilt truck box in the fully down position as not to be subjected to possible free fall. Personnel should never occupy the space below an elevated load.
7. After locking and tagging the dumper, ensure that the dumper is disconnected from the energy source by first checking that no personnel are exposed, then verify the isolation of the equipment by operating the push button or other normal operating control(s) or by testing to make certain the equipment will not operate. Try to start and operate the dumper (as outlined in the Operating Instructions) to make sure the Lock-Out and Tag-Out is effective. If the Lock-Out and Tag-Out is effective, remove the key from the key switch and take it with you.
8. Before servicing dumper perform hazard assessment for confined space requirements (hazardous fumes, dust, toxic material, or other hazards) per the OSHA confined space standard.
9. The dumper is now locked out.

# Electric Container Dumper

## General Information

### LOCK-OUT & TAG-OUT INSTRUCTIONS (CONTINUED)

#### RESTORING SERVICE

When the servicing or maintenance is completed, and the dumper is ready to return to normal operating condition, the following steps shall be taken:

1. Check the dumper and the immediate area around the dumper to ensure that nonessential items have been removed and that the dumper components, guards and covers are operationally intact.
2. Check the work area to ensure that all employees have been safely positioned or removed from any hazardous area.
3. Verify that the controls are in neutral.
4. Remove the lockout devices and re-energize the dumper.
5. Notify affected employees that the servicing or maintenance is completed, and the dumper is ready for use.
6. Reassess area to determine all hazards are protected.

# Electric Container Dumper

## General Information

### COMPONENTS

#### **WARNING**

Never perform any maintenance on any part of the dumper until the dumper has been locked out and tagged out.

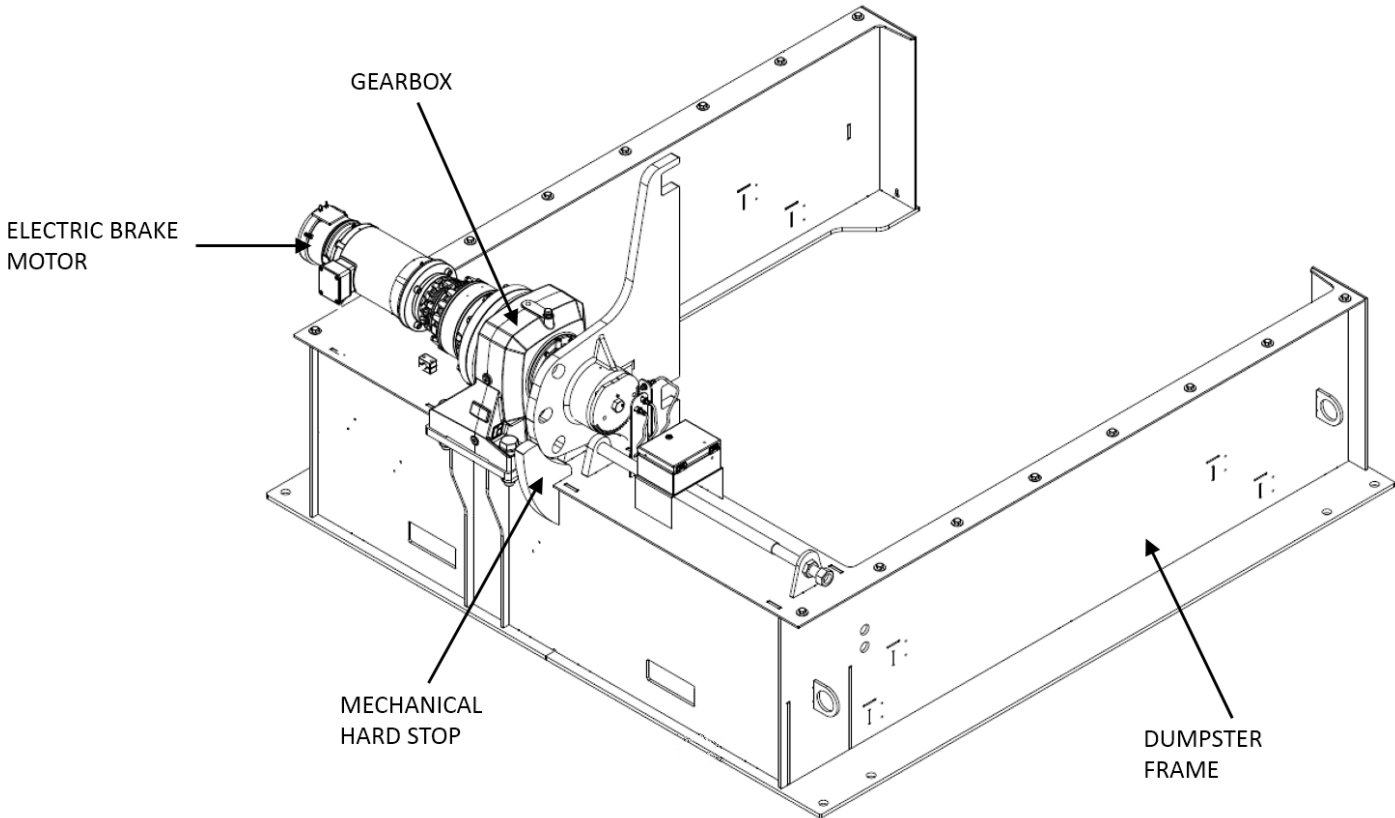

# Electric Container Dumper

## General Information

### COMPONENTS (CONTINUED)

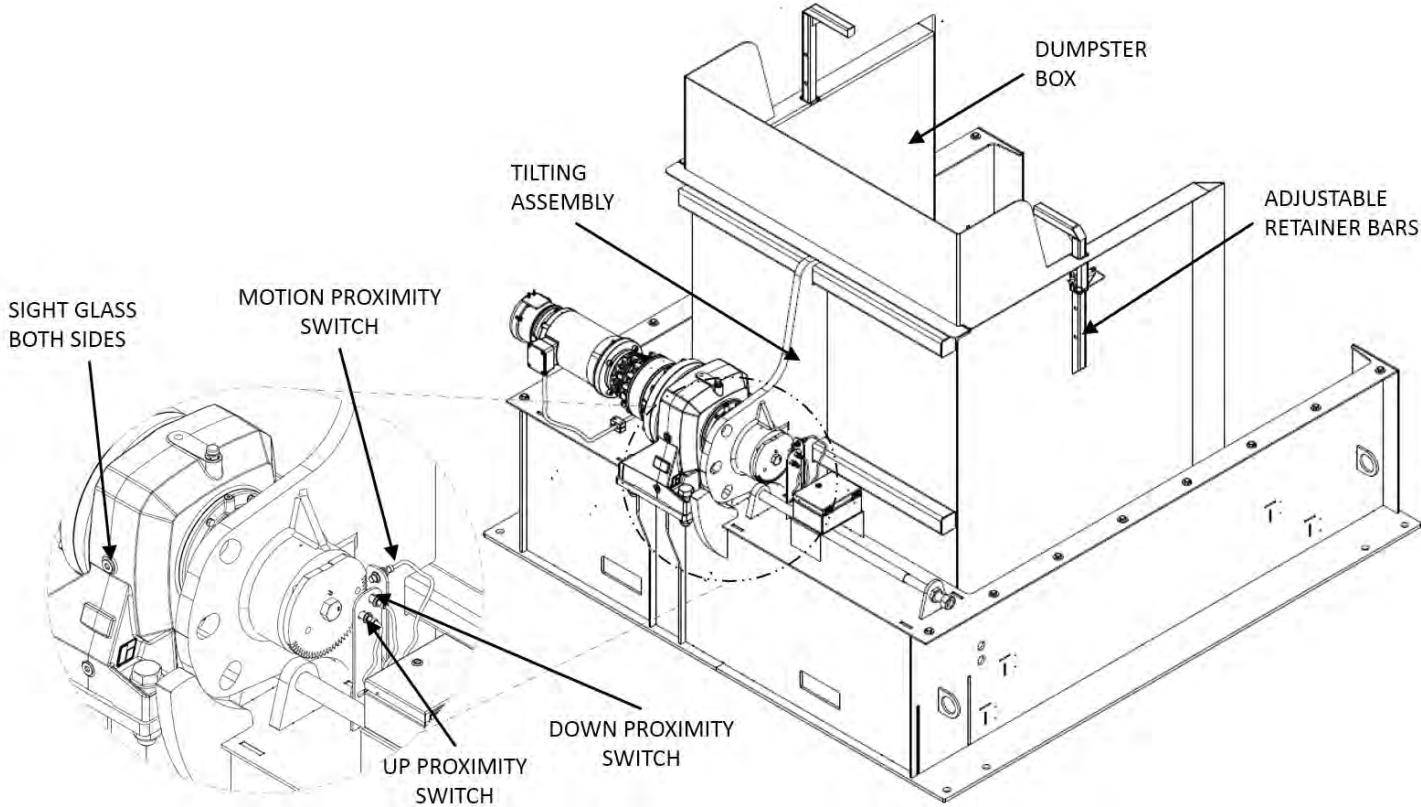

# Electric Container Dumper

## General Information

### COMPONENTS (CONTINUED)

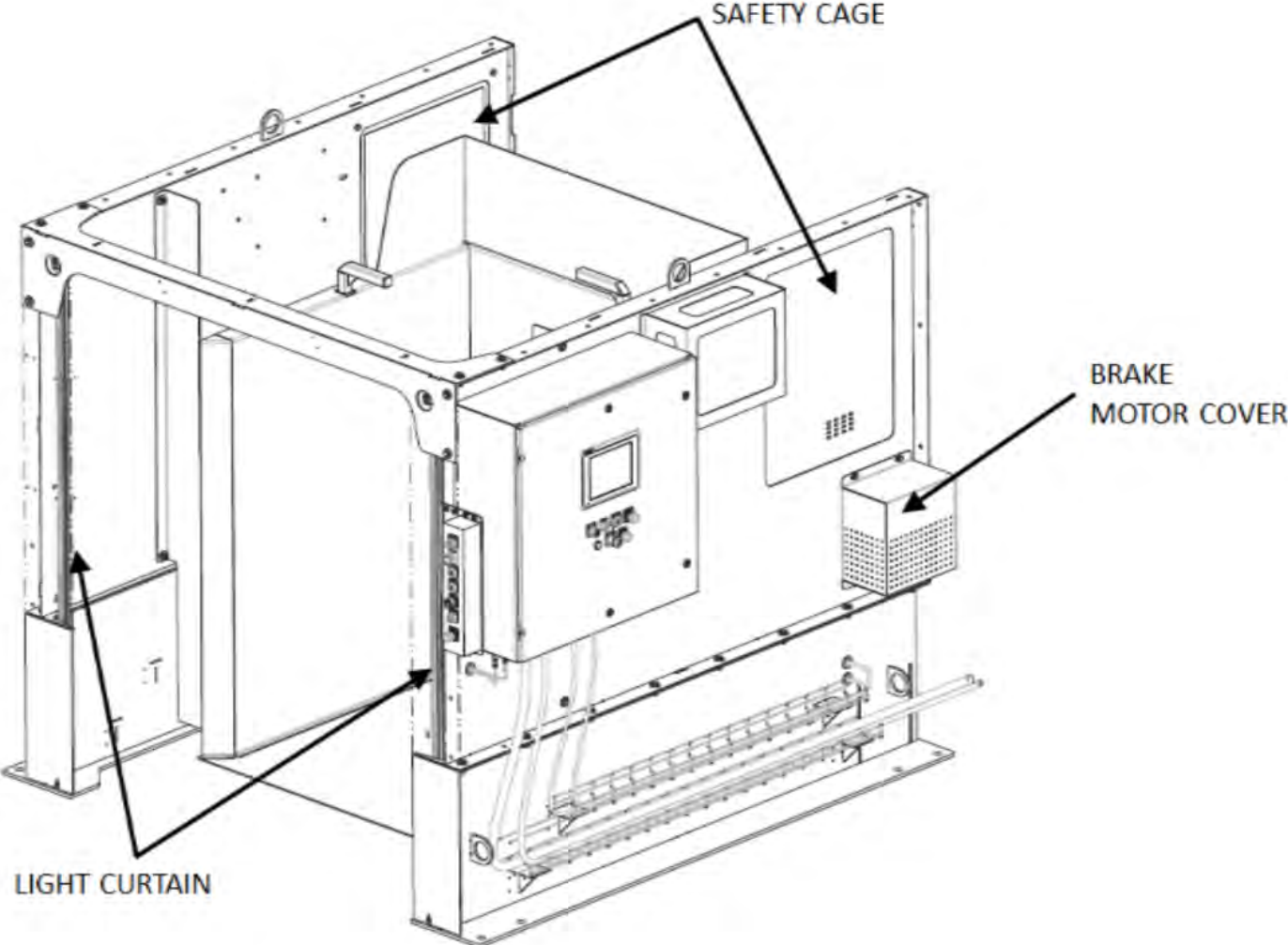

# Electric Container Dumper

## General Information

### COMPONENTS (CONTINUED)

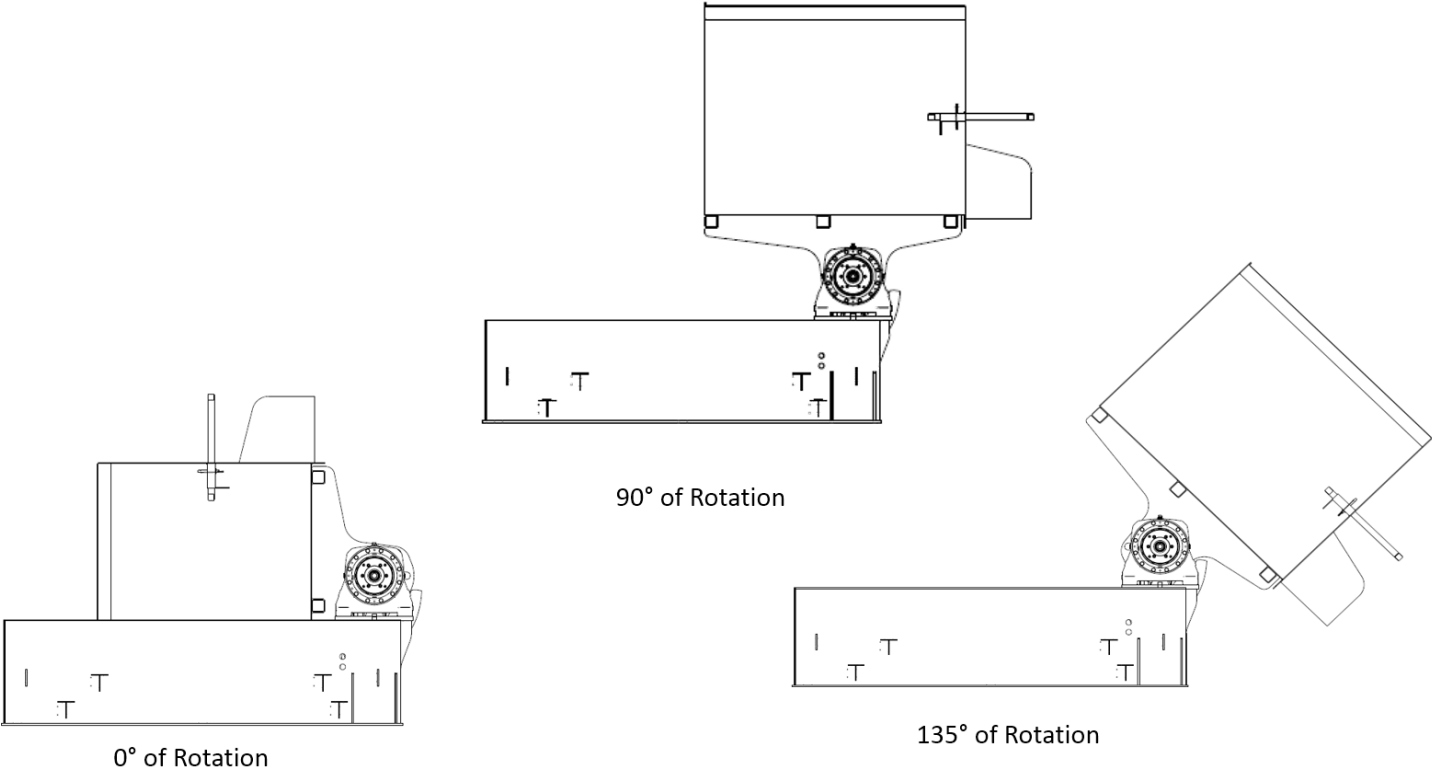

# Electric Container Dumper

## General Information

### SERVICE/PARTS ASSISTANCE

Assistance in troubleshooting, repair and service is available by contacting the authorized Marathon Equipment Company Dealer in your area. Parts are available at your Marathon Equipment Company Dealer or through Marathon Equipment Company. Marathon Equipment Company personnel are trained to give prompt, professional assistance.

ALWAYS give the machine serial number in all correspondence relating to the equipment.

### GUARDS AND ACCESS COVERS

Before operating or performing maintenance, check the work area carefully to find all the hazards present and make sure all guards and safety devices are in place to protect all persons and equipment involved.

#### **WARNING**

---

DO NOT operate without all guards and access covers in place.

---

### GREASE LUBRICANT RECOMMENDATION

Use a grease gun. Before engaging grease gun, clean the fitting. Always pump enough grease to purge the joint of contaminated grease and wipe off the excess grease. Lubricate a unit as recommended on the lubrication decal on the unit and in the Operation, Service, and Installation Manual.

### RECOMMENDED GEARBOX OILS

The following oils by brand name are approved for use in the hydraulic system on this equipment and considered to be all temperature hydraulic fluids.

- Valvoline EPG Gear Lube 320 rated 15 to 160 degrees Fahrenheit
- Valvoline EPG Gear Lube 220 rated 0 to 130 degrees Fahrenheit
- Valvoline EPG Gear Lube 150 rated -22 to 90 degrees Fahrenheit

Note: all gearboxes ship filled with Valvoline EPG Gear Lube 320

### RECOMMENDED MOTOR GREASE

- Mobil Polyrex EM



### WARNING DECALS ON THE UNIT

#### **WARNING**

DO NOT operate without all guards and access covers in place.

---

Make sure you can read all warning and instruction decals. Clean decals if you cannot read the words. See below for directions on cleaning decals. Replace any decal that is damaged, missing, or is not readable. When you replace a part that has a decal, make sure a new decal is installed on the new part. See the Operation, Service, and Installation Manual for replacement decals. Order replacement decals from Marathon Equipment Company or an authorized dealer.

### DECAL CARE

It is important that the decals are properly cleaned to make sure that they are readable and do not come off the unit. Use the following steps to clean the decals.

#### A. General Instructions

Following these instructions helps the decals adhere longer.

- Wash the decals with a blend of mild car wash detergent and clean water
- Rinse with clean water
- Let the unit air-dry or dry with a micro-fiber cloth
- Do not allow fuels to stay in contact with the decal for an extended period of time. Remove the fuel contamination as quickly as possible
- Do not use carnauba-based wax over the decals
- Do not use a mechanical brush while washing the decals.

#### B. Pressure Washer Precautions

Pressure washing can cause damage to decals. It can cause the edges of the decals to lift and peel the decal away from the unit. Over time, the decal can fade, crack or chip away.

Use pressure washing only when other cleaning methods are not effective. If you use a pressure washer, use the following precautions.

- Spray nozzle opening: 40° wide pattern
- Spray angle: 65° from unit's body
- Distance of nozzle to decal: 15" minimum
- Water pressure: less than or equal to 800 psi
- Length of time: not more than 30 sec.
- Do not use sharp angles to clean the decals – this can lift the decals from the unit.
- NEVER use a "turbo pressure nozzle".

#### C. Remove Difficult Debris

When normal cleaning procedures do not remove difficult debris from the decals, try the following:

- Spot clean the decal with Isopropyl Alcohol and a micro-fiber cloth (rag)
- If these methods do not work on a problem area, call a Marathon Equipment Company Dealer or Marathon Equipment Company Customer Support.

# Electric Container Dumper





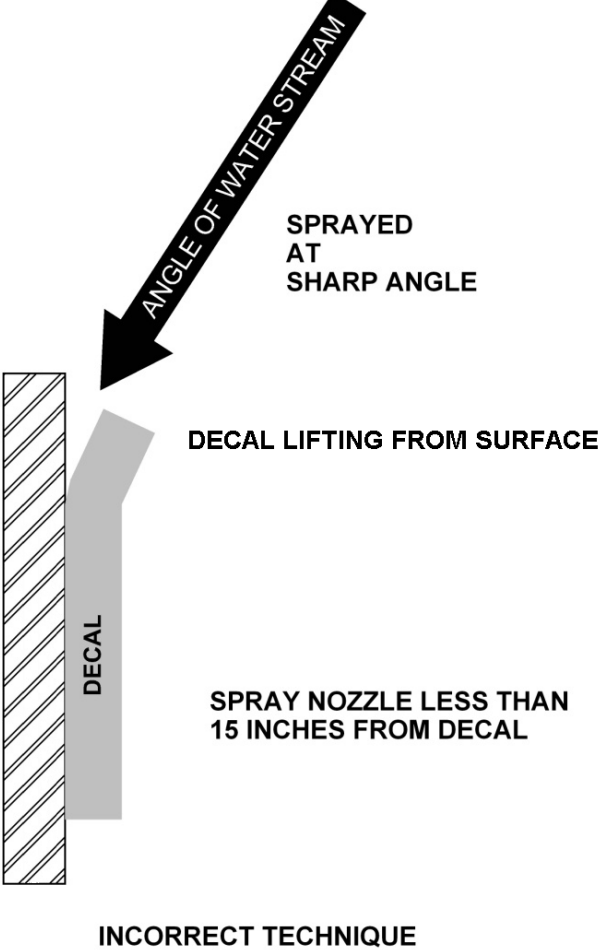
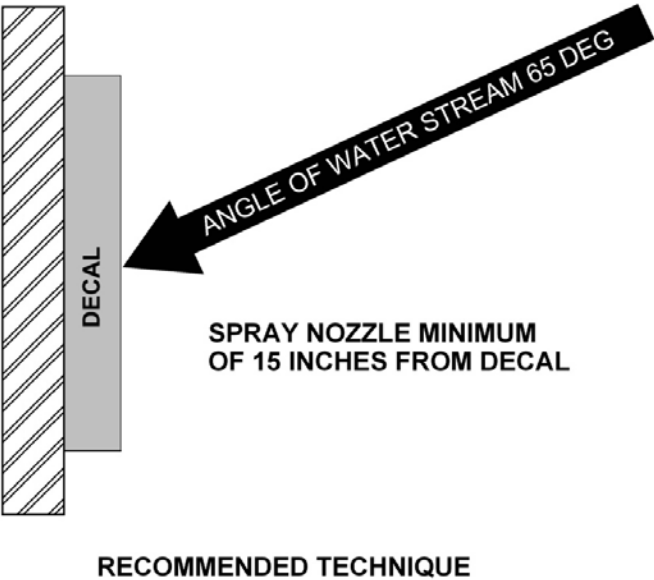







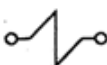

## General Information

### DECAL CARE (CONTINUED)

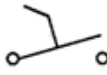

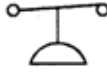
**ELECTRICAL SYMBOLS**

**SYMBOL DEFINITIONS**

	<b>BATTERY</b>
	<b>FUSE</b>
	<b>SOLENOID</b>
	<b>CONTACT RELAY</b>
	<b>NORMALLY OPEN CONTACT OF CR1</b>
	<b>NORMALLY CLOSED CONTACT OF CR1</b>
	<b>INDICATOR LIGHT (GREEN)</b>
	<b>PUSH BUTTON SWITCH NORMALLY CLOSED</b>
	<b>PUSH BUTTON SWITCH NORMALLY OPEN</b>
	<b>TOGGLE SWITCH</b>
	<b>DIODE</b>
	<b>PRESSURE SWITCH</b>
	<b>LIMIT SWITCH NORMALLY OPEN</b>
	<b>LIMIT SWITCH NORMALLY CLOSED</b>
	<b>CAPACITOR</b>

**INTENTIONALLY LEFT BLANK**

# **SECTION 2**

# **INSTALLATION**

**CONTACT INFORMATION**



Technical Service and Warranty:

**877-258-1105**

Parts:

**800-528-5308**

For parts visit our eCommerce Marketplace at [www.mecomerchant.com](http://www.mecomerchant.com).

If you do not have a user name and password, contact our Parts Department and they will assist with your registration.

**Normal Business Hours:**

**Monday-Friday            8:00am - 5:00pm**

**(Central Standard Time)**

### CONCRETE PAD REQUIREMENTS

#### CAUTION

Review this manual before starting the installation. Study the job site and installation requirements carefully to be certain all necessary safeguards and or safety devices are provided to protect all personnel and equipment during the installation and as a completed system. Special attention is directed to the most current ANSI Z245.2 standard.

Marathon Equipment Co. does not assume responsibility for the installation procedures of this equipment. Conformance to applicable local, state, and federal laws concerning installation rests with the customer.

#### Concrete Pad

It is realized that in most installations the concrete pad is designed to accommodate a compactor and container. To accommodate the dumper system, the preferred dimensions of the concrete pad should be 5'0" greater than the width of the dumper and should extend out in front of the dumper to adequately accommodate the dumper cart, guard rails, and any towing vehicle. The pad should be of minimum 3,000 PSI concrete steel reinforced, 6" thick. It is preferred that the concrete pad be flush with the surrounding ground level.

#### NOTICE

The clearances given are minimums. Your installation may require greater clearances depending on the site and the hauling equipment that will be used.

#### Anchoring

The dumper should be anchored to concrete pad using (8) min. 1" x 6" long anchor bolts. These holes should be drilled in the concrete after placing the dumper in its desired location. Holes in the leg plates are 1 1/8" dia. to permit the use of a 1" dia. concrete bit. The 1" dia. holes in the concrete should be approximately 5" deep. When the dumper has been permanently located, shimmed to compensate for unevenness, and anchor bolts set, tighten all nuts securely.

#### Decals

Be certain that the appropriate decals are always in their proper locations at all times on the machine. For decal locations, see Decals and Decal Placement in the Replacement Parts section of this manual.

#### Guarding for Automatically Operated Dumpers

The dumper should be enclosed by guards, cage, light curtains, or other similar devices a minimum of 84" high with interlocked access that prevent entry or operation when not in place.

# Electric Container Dumper Installation

## ELECTRICAL INSTALLATION

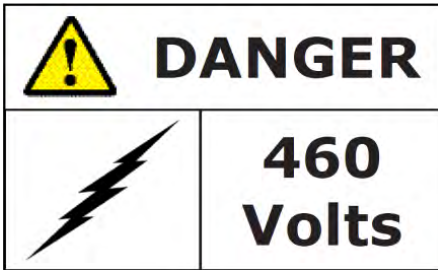

The panel box contains high voltage components. Only authorized service personnel should be allowed inside. See **Lock-Out & Tag-Out Instructions** in the service section.



A lockable fused disconnect switch (customer furnished) must be installed and be within sight of the dumper's electrical panel box location, not to exceed 50'0" from the dumper. This fused disconnect switch should be sized in accordance with the dumper (see **Fuse and Circuit Breaker Chart**).

### **WARNING**

---

All equipment should be grounded per National Electric Code.

---

### **Grounding Instructions**

This appliance must be connected to a grounded, metal, permanent wiring system; or an equipment grounding conductor must be run with the circuit conductors and connected to the equipment grounding terminal or lead on the appliance.

If there is any doubt whether the equipment is properly grounded, a qualified electrician should be consulted.

### **Electrical Connections**

1. Run power lines between fused disconnect switch (customer furnished) and dumper's electrical panel box, in accordance with local electrical codes, using knock-outs in bottom of panel box. See Fuse and Circuit Breaker Chart for Motors and Wire Size Chart, in the service Section, to determine the proper service disconnect amperage rating and the proper wire size.

### **NOTICE**

---

High legs should be installed to L3 on motor starter.

---

2. Check voltage at fused disconnect switch to be certain it is the same as shown on the dumper.



# Electric Container Dumper Installation

## ELECTRICAL INSTALLATION (CONTINUED)

### Start-Up Instructions

Ensure gearbox is full of oil prior to operation. Check fluid level using the sight gauge on the side of the gearbox. Fluid level should be to the top of the sight gauge. Refer to "Recommended Gearbox Oils" <sup>(12)</sup> if oil is needed.

---

** CAUTION**

Make sure the brake on the motor is engaged.

---

** CAUTION**

Make sure persons and material are clear of the dumper area.

---

Put the dumper in manual mode. Turn the switch in the up position to check motor rotation. If motor rotates backwards stop immediately. Reversing any two incoming power lines will change the motor rotation. Make sure that the operators are trained in the proper use of this equipment.

**INTENTIONALLY LEFT BLANK**

# **SECTION 3**

# **OPERATION**

**CONTACT INFORMATION**



Technical Service and Warranty:

**877-258-1105**

Parts:

**800-528-5308**

For parts visit our eCommerce Marketplace at [www.mecomerchant.com](http://www.mecomerchant.com).

If you do not have a user name and password, contact our Parts Department and they will assist with your registration.

**Normal Business Hours:**

**Monday-Friday            8:00am - 5:00pm**

**(Central Standard Time)**

# Electric Container Dumper

## Operation

### PRE-OPERATION INSTRUCTIONS

Employers should allow only authorized and thoroughly trained personnel to operate this container dumper.

This cart dumper is equipped with a key operated locking system. Keys should be in possession of only authorized personnel. Turn off and remove the key after use.

#### **DANGER**

ONLY TRAINED AND AUTHORIZED PERSONNEL SHOULD BE ALLOWED INSIDE PANEL BOX. The panel box contains high voltage components. See **Lock-Out/Tag-Out Instructions**.

#### **DANGER**

Personnel should never occupy the space below an elevated load. Doing so could result in serious personal injury or death!

#### **WARNING**

Stay clear of all parts of the dumper during operation. Failure to do so could result in serious personal injury or death!

#### **WARNING**

Never enter the area around the dumper unless the Lock-Out/Tag-Out instructions have been completed. See **Lock-Out/Tag-Out Instructions**.

#### **WARNING**

Before starting the dumper, be sure no one is around the dumper. Be certain that everyone is clear of all operation points and pinch point areas before starting.

#### **WARNING**

If the dumper is equipped with a security gate, be sure that the security gate is closed before the dumper is started.

#### **NOTICE**

Federal regulation prohibits the use of this equipment by anyone under 18 years of age.

#### **WARNING**

If the dumper is equipped with a security gate, be sure that the security gate is closed before the dumper is started.

#### **WARNING**

The employer should allow only authorized and trained personnel to operate this dumper. This dumper is equipped with a key operated locking system. The key(s) should only be in the possession of authorized personnel.

# Electric Container Dumper Operation

## CONTROL PANEL FOR DUMPERS WITH MANUAL CONTROLS

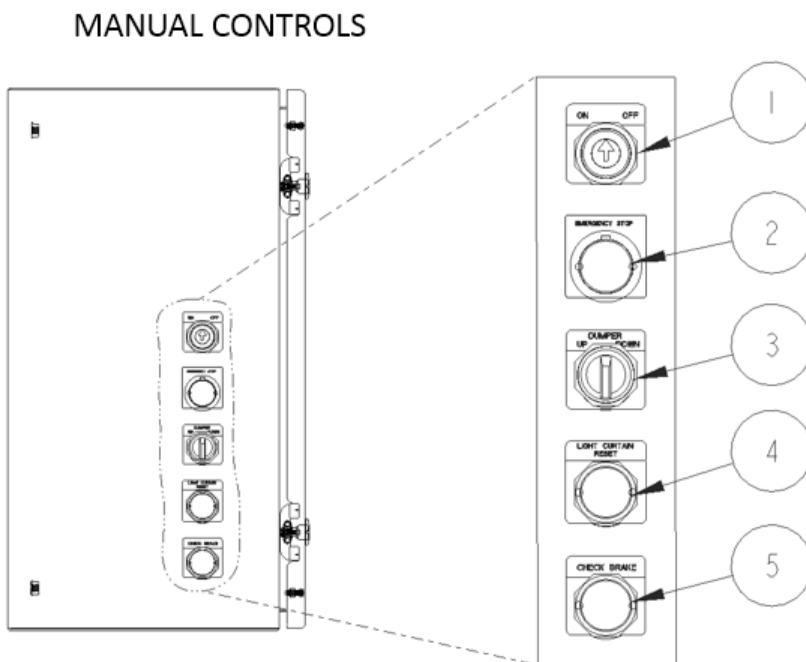

### Control Description

1. ON/OFF KEY SWITCH – This switch requires a key for operation. Insert the key and turn counterclockwise to turn the dumper on. Once dumper use is completed turn the key clockwise and remove the key from the switch.
2. EMERGENCY STOP PUSH BUTTON – When depressed this push button will stop all powered operation of the dumper. Pull push button out to reset.
3. DUMPER UP/DOWN SPRING CENTERED SWITCH – Turn and hold this switch counterclockwise to raise the dumper. Turn and hold this switch clockwise to lower the dumper. When released this switch will automatically return to the center position.
4. LIGHT CURTAIN RESET ILLUMINATED PUSH BUTTON – When the light curtain is tripped, this amber push-button will illuminate. Depress the amber push button to reset the light curtain.
5. CHECK BRAKE PUSH BUTTON – When the system detects brake motor slippage, this red push-button will illuminate. After brake maintenance is performed, depress the red push button to reset the check brake light.

# Electric Container Dumper Operation

## CONTROL PANEL FOR DUMPERS WITH AUTO-CYCLE FUNCTION

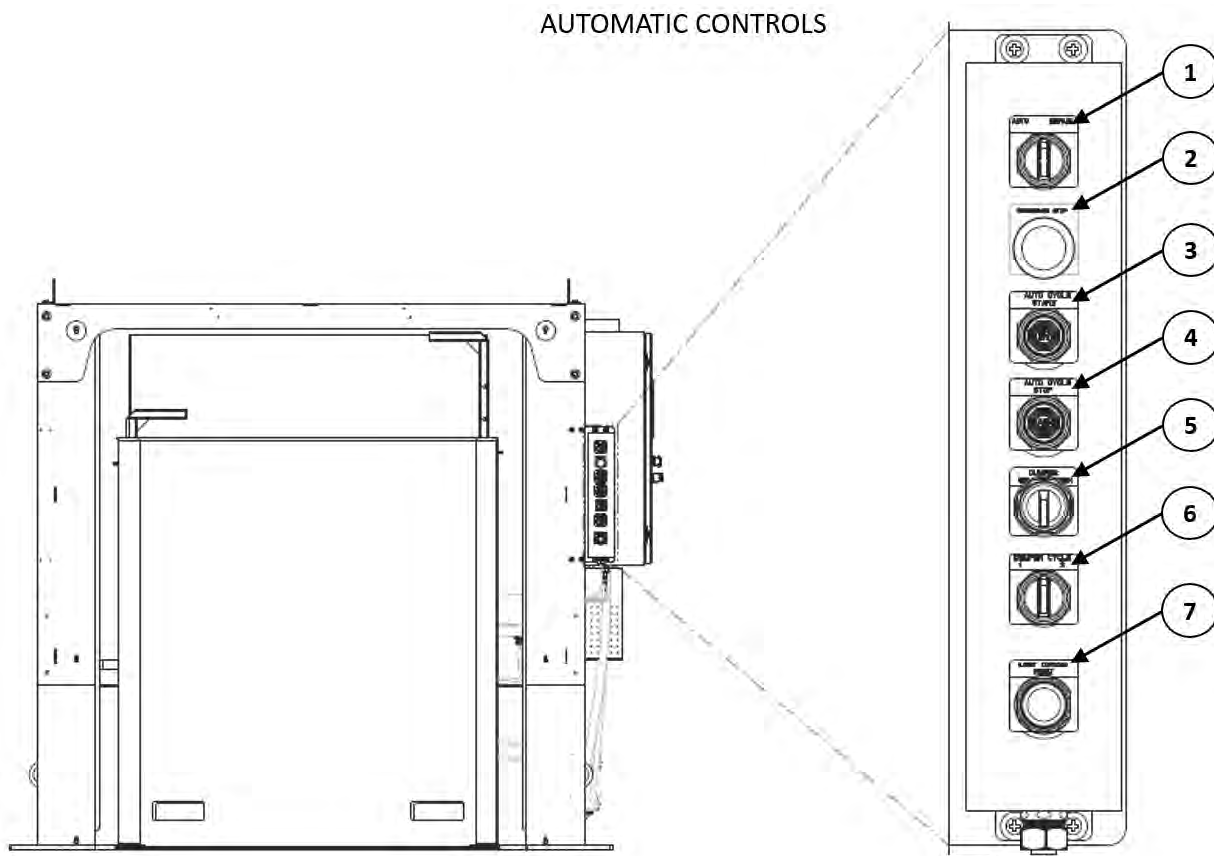

### Control Description

1. **AUTO MANUAL SELECTOR SWITCH-** This switch allows you to set the dumper operation in automatic or manual mode.
2. **EMERGENCY STOP PUSH-BUTTON-** When depressed, this push-button will stop all powered operation of the dumper.
3. **AUTO CYCLE START-** With the auto manual switch in automatic mode, press this push-button and hold for 5 seconds to start an auto cycle.
4. **AUTO CYCLE STOP-** When in operating in automatic mode press this push-button to stop the dumper's automatic cycle.
5. **DUMPER UP/DOWN SPRING-CENTERED SELECTOR SWITCH-** With the auto manual switch in manual mode, turn and hold this switch counterclockwise to raise the dumper. Turn and hold this switch clockwise to lower the dumper.
6. **DUMPER SINGLE OR DUAL CYCLE SELECTOR SWITCH-** With the dumper in automatic mode, this switch allows you to select the number of cycles that the dumper will operate.
7. **LIGHT CURTAIN RESET ILLUMINATED PUSH-BUTTON-** When the light curtain is tripped, this amber push-button will illuminate. Depress the amber push-button to reset the light curtain.

# Electric Container Dumper

## Operation

### TOUCH SCREEN CONTROL (IF EQUIPPED)

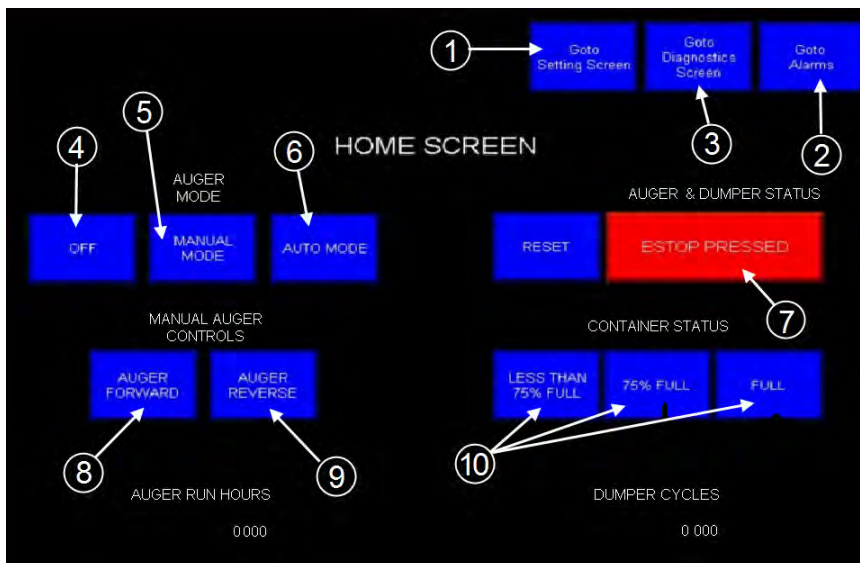

### Control Description

1. **GOTO SETTING SCREEN** - Touching this button will take you to the Setting Screen. From this screen you can adjust the settings of the auger and dumper. This screen is password protected and should only be accessed by authorized personnel.
2. **GOTO ALARMS** - Touching this button will take you to the Alarm Screen. From this screen you can view both active and past alarms, the acknowledgment status, time and date, and the time and date the alarm occurred. Alarms can also be acknowledged and cleared from this screen.
3. **GOTO DIAGNOSTICS SCREEN** - Touching this button will take you to the Diagnostics Screen. From this screen you can check the status of the proximity switches and upper and lower photocell.
4. **COMPACTOR MODE, ON/OFF INDICATOR** - This indicator displays the state of the auger, either ON or OFF.
5. **MANUAL MODE SELECTOR** - Touching this button will place the auger in manual operation mode.
6. **AUTO MODE SELECTOR** - Touching this button will place the auger in automatic operation mode. In order for the auger to be placed into automatic the button must be held for 20 seconds. During the initial 5 seconds an alarm will sound to warn personnel that the auger is being started. A green flashing beacon will also give an indication that the auger is in automatic mode. Once placed in automatic mode the auger will start when signaled by the photocell that the charge chamber has material in it.
7. **COMPACTOR STATUS DISPLAY** - This display shows the current condition of the auger. If any alarm exists, it will be displayed here. To view and acknowledge alarms go to the ALARMS screen. To reset alarms, go to the Alarms screen.  
  
Note: Alarms can only be reset once they have been acknowledged and the condition that caused the alarm has been corrected.
8. **AUGER FORWARD** - Touching this button will start the auger in the forward direction. Note: This control is only active in the MANUAL MODE.
9. **AUGER REVERSE** - Touching this button will start the auger in the reverse direction. Note: This control is only active in the MANUAL MODE.
10. **CONTAINER FULLNESS STATUS** - These indicators show the fullness status of the container. Each level of fullness, when activated, will illuminate green to indicate the status of the container. When the container is full or if a jam occurs in the auger the FULL indicator will illuminate green and the auger will shut down.



# Electric Container Dumper Operation

## TOUCH SCREEN CONTROL (CONTINUED)

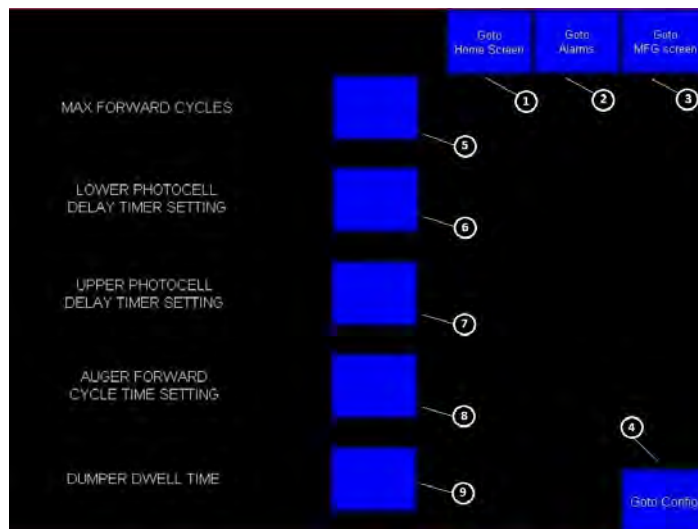

### Control Description

1. GOTO HOME SCREEN -Touching the GOTO HOME SCREEN button will return you to the Home Screen.
2. GOTO ALARMS -Touching this button will take you to the Alarm Screen. From this screen you can view both active and past alarms, the acknowledgment status, time and date, and the time and date the alarm occurred. Alarms can also be acknowledged and cleared from this screen.
3. GOTO MFG SCREEN -The GOTO MFG SCREEN is used by Marathon Equipment Company to enter information into the PLC program for the particular application the auger will be used in. This screen is password protected and should only be accessed by authorized personnel.
4. LOGOUT-This button is used to access the configuration of the touch screen. It should not be accessed by anyone unless directed to do so by someone at Marathon Equipment Company.
5. MAX FORWARD CYCLES -This setting will determine the maximum number of cycles the Auger Compactor can make during an auto cycle. For instance, if the Max Cycles is set to 3 the auger will shut down after the 3 forward cycle. To adjust this setting touch the blue box next to the caption and a numerical entry pad will pop up on the screen. The minimum value that can be entered is 1 and the maximum value is 6. The number entered will be displayed in the blue box next to the caption.
6. LOWER PHOTOCELL DELAY TIMER SETTING -This is used to adjust the amount of time it takes the auger to start up after the lower photocell has been blocked. To adjust this setting touch the blue box next to the caption and a numerical entry pad will pop up on the screen. The minimum value that can be entered is 1 second and the maximum is 5 seconds. The number entered will be displayed in the blue box next to the caption.
7. UPPER PHOTOCELL DELAY TIMER SETTING-This is used to adjust the amount of time it takes to signal that the upper photocell has been blocked. This signal is used to stop or start a conveyor or other device that may be used to feed material into the auger. To adjust this setting touch the blue box next to the caption and a numerical entry pad will pop up on the screen. The minimum value that can be entered is 1 second and the maximum is 10 seconds. The number entered will be displayed in the blue box next to the caption.
8. AUGER FORWARD CYCLE TIME SETTING -This setting is used to adjust the amount of time the auger runs in the forward direction. To adjust this setting touch the blue box next to the caption and a numerical entry pad will pop up on the screen. The minimum value that can be entered is 30 seconds and the maximum is 300 seconds. The number entered will be displayed in the blue box next to the caption.
9. DUMPER DWELL TIME -This setting is used to adjust the amount of time the dumper holds in the full up position before it returns down. To adjust this setting touch the blue box next to the caption and a numerical entry pad will pop up on the screen. The minimum value that can be entered is 1 second and the maximum is 5 seconds. The number entered will be displayed in the blue box next to the caption.

# Electric Container Dumper Operation

## TOUCH SCREEN CONTROL (CONTINUED)

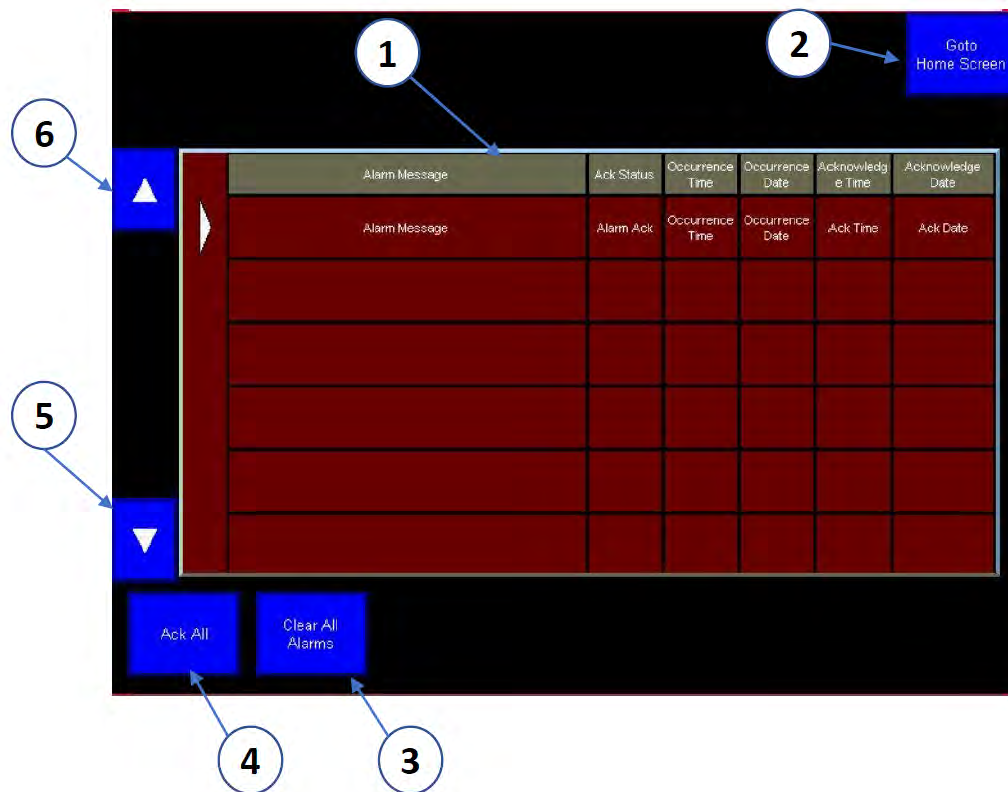

### Control Description

1. **ALARM MESSAGE BOX** The Alarm Message Box is the area where alarms will be displayed. Other information such as Alarm Acknowledgment Status, Occurrence Time, Occurrence Date, Acknowledge Time, and Acknowledge Date is also displayed here.
2. **GOTO HOME SCREEN** Touching this button will return you to the Home Screen.
3. **CLEAR ALL ALARMS** This button is used to clear all alarms from the Alarm Message Box. Once cleared the alarm information cannot be retrieved.
4. **ACK ALL** This button is used to acknowledge an active alarm. When touched it enters the time and date that the alarm was acknowledged and changes the acknowledge status to Alarm Acknowledged. It does not reset the alarm condition.
5. **SCROLL DOWN** Use this button to scroll down through the Alarm Message list
6. **SCROLL UP** Use this button to scroll up through the Alarm Message list..

# Electric Container Dumper Operation

## TOUCH SCREEN CONTROL (CONTINUED)

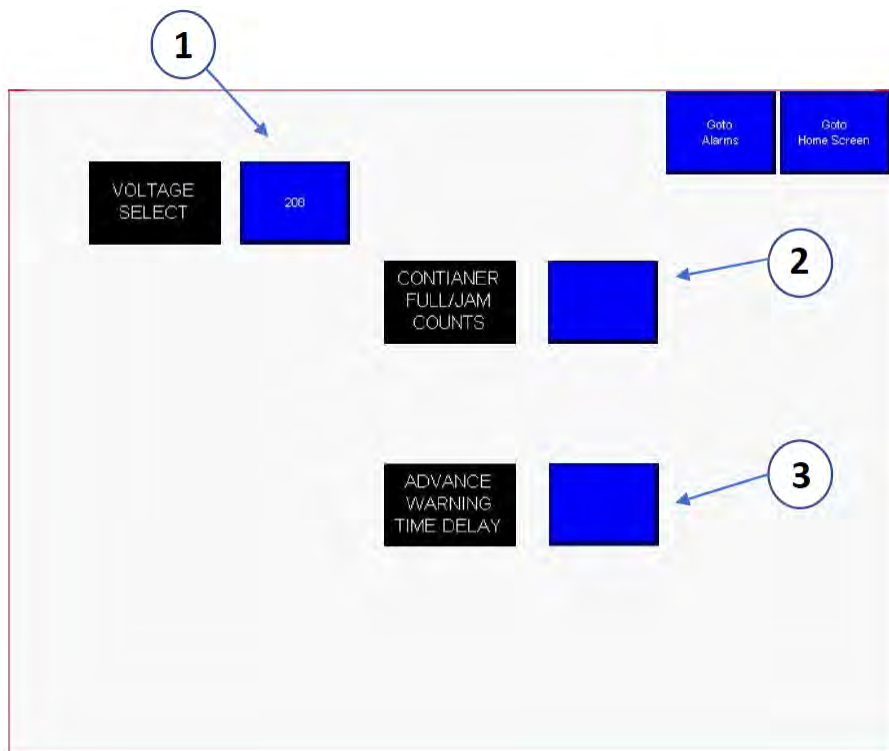

### Control Description

Note: This screen is used during the mfg process to set the auger up and should not be accessed by anyone unless authorized by someone at Marathon Equipment Company.

1. VOLTAGE SELECT-Touching this button will allow trained maintenance or service personnel to set the proper voltage for the machine.
2. CONTAINER FULL/JAM COUNTER-Touching this button will allow the trained maintenance or service personnel to set the number of container full indicators. Container full counter can be set to 1-3 counts.
3. ADVANCED WARNING TIME DELAY-Touching this button will allow the trained maintenance or service personnel to set the time delay on the advanced warning. The time delay can be set to 1-4 seconds.

# Electric Container Dumper

## Operation

### OPERATING INSTRUCTIONS FOR DUMPER

#### CAUTION

Before operating the dumper, make sure that all persons and items other than the dumper cart and its contents are clear of the dumper and dumping area.

#### WARNING

Before operating the dumper, make sure that the dumper cart is compatible with the dumper. never attempt to dump a cart not specifically designed for the dumper.

#### NOTICE

If the dumper is equipped with an access gate, make sure that the access gate is closed before operating the dumper.

**IN CASE OF EMERGENCY: Push the large RED button to STOP!**

### Sustained-Manual-Pressure Control Operation Instructions

1. Make sure all E-Stop buttons are pulled out. Using the auger compactor controls make sure the E-Stop circuit is reset. If the amber Safety Relay Reset push button is illuminated push it in until the amber light turns off.
2. Push cart onto dumper this will break the light curtain, causing the amber Light Curtain Reset light on the control panel to illuminate.
3. Reset the light curtain by pushing in on the amber Light Curtain Reset illuminated push-button, until the light turns off.
4. Place the Dumper Auto/ Manual selector switch (if equipped) in the manual position.
5. Use the Dumper Up/ Down selector switch to raise and lower the dumper as needed.
6. The dumper will stop lifting when the up proximity switch is actuated. The dumper will stop lowering when the down proximity switch is actuated.

# Electric Container Dumper

## Operation

### OPERATING INSTRUCTIONS FOR DUMPER (CONTINUED)

#### Automatic Control Operation Instructions (if equipped)

1. Make sure all E-Stop buttons are pulled out. Using the auger compactor controls make sure the E-Stop circuit is reset. If the amber Safety Relay Reset push button is illuminated push it in until the amber light turns off.
2. Place the auger in automatic mode by pressing and holding the Auto Mode button on the touch screen Home screen for 20 seconds. An alarm will sound for 5 seconds and the green strobe light will flash as long as the auger remains in automatic. The auger will start.
3. Push cart onto dumper this will break the light curtain, causing the amber Light Curtain Reset light on the control panel to illuminate.
4. Reset the light curtain by pushing in the amber Light Curtain Reset illuminated push-button, until the light turns off.
5. Place the Dumper Auto/ Manual selector switch (if equipped) in the Auto position.
6. Choose one or two cycles for the dumper to make by setting the Dumper Cycle selector switch. If two cycles are selected, the dumper will move to fully up position and then move partially down before going back to the fully up position. The dumper will lower when the second cycle is complete. If one cycle is selected, the dumper will move to the fully up position and then back to the down position.
7. Press the Auto Cycle push button for 5 seconds. The dumper will make one or two cycles depending on the setting of the of the Dumper Cycle selector switch. (Note: If the dumper cycle is interrupted by breaking the light curtain during an auto cycle, the auger and the dumper will be taken out of automatic and stop. The Dumper Auto/ Manual selector switch must be turned to manual and the dumper lowered to the full down position using the Up/ Down selector switch before the unit can be put back in auto.
8. The dumper will stop lifting when the up proximity switch is actuated. After a short pause the dumper will lower. The dumper will stop lowering when the down proximity switch is actuated.
9. When the auto cycle is completed, the cart can be removed from the dumper.

## AUTOMATIC OPERATION TROUBLESHOOTING GUIDE

**STEP ONE** - Make sure all E-Stop buttons are pulled out. Using the auger compactor controls, make sure the E-Stop circuit is reset. If the amber SAFETY RELAY RESET light is illuminated press it to reset the safety monitoring relay. The light will go off when it is reset. Touch the RESET button on the touch screen under COMPACTOR STATUS to reset any alarms on the touch screen.



**Figure 1**

Figure 1: If the amber light does not go off once the button is depressed, check all E-stops to ensure that they are pulled out.

There are a total of 3 E-stops on the unit:

1. Located on the main control panel face.
2. Located on the remote push button station.
3. Located on the right side of the auger body.



# Electric Container Dumper Operation

## AUTOMATIC OPERATION TROUBLESHOOTING GUIDE (CONTINUED)



If all E-stops have been checked and verified that they are all pulled out, and the amber reset light does not go off after the push button is depressed, call Marathon Technical Service 877-258-1105.

# Electric Container Dumper Operation

## AUTOMATIC OPERATION TROUBLESHOOTING GUIDE (CONTINUED)

**STEP TWO** - Place the auger in automatic mode by pressing and holding the Auto Mode button on the touch screen Home screen for 20 seconds. An alarm will sound for 5 seconds and the green strobe light will flash as long as the auger remains in automatic. The auger will start.

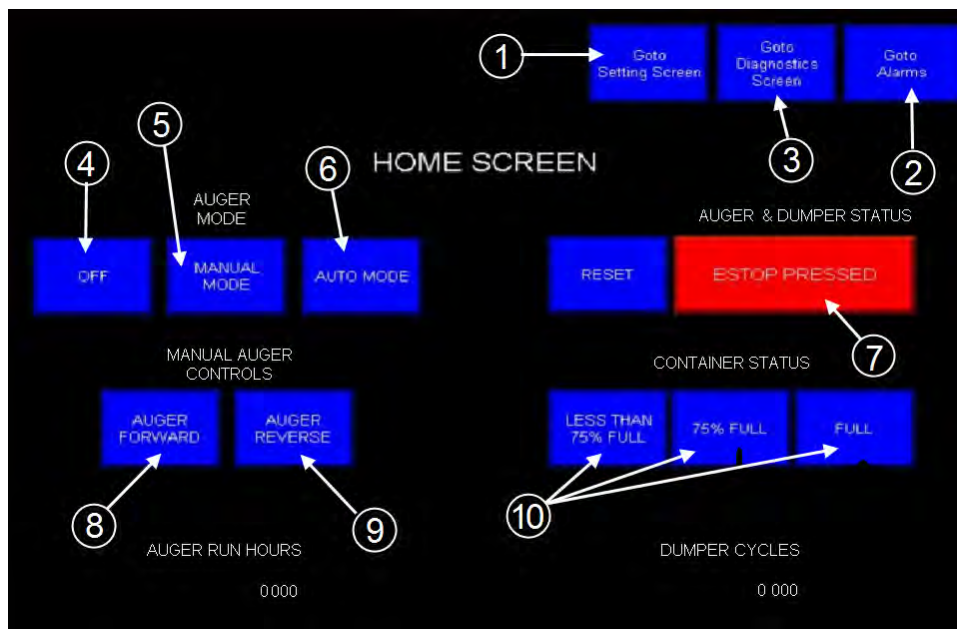

If the alarm does not begin to sound when the auto button is depressed check the alarm banner on the touchscreen. The following faults could prevent you from starting in automatic.

- ESTOP PRESSED
- LIGHT CURTAIN TRIPPED
- MULTIPLE FAULTS



# Electric Container Dumper Operation

## AUTOMATIC OPERATION TROUBLESHOOTING GUIDE (CONTINUED)

The alarm banner must read COMPACTOR OK and the dumper be in the full down position to start up in automatic.  
If the alarm banner reads COMPACTOR OK and the unit will not start the automatic sequence, check all the alarm lights on the panel box face and the remote controls pendent.



If the safety relay rest amber push button is illuminated, refer back to Figure 1 to check all of the E-Stop circuits.



If the Overload Tripped amber push button is illuminated, depress the button to reset the overload light. If the overload illuminated push button does not reset call Marathon Technical Service 877-258-1105.

# Electric Container Dumper Operation

## AUTOMATIC OPERATION TROUBLESHOOTING GUIDE (CONTINUED)



If the Container Gone Red push button is illuminated, confirm that the container has been replaced on the compactor and depress the push button to reset the container gone function.



If the container has been replaced, and depressing the container gone push button does not reset the illuminated red light, inspect the container gone sensor for damage. The sensor is located on the compactor hopper body. If no damage is discovered, call Marathon Technical Service 877-258-1105.

# Electric Container Dumper Operation

## AUTOMATIC OPERATION TROUBLESHOOTING GUIDE (CONTINUED)

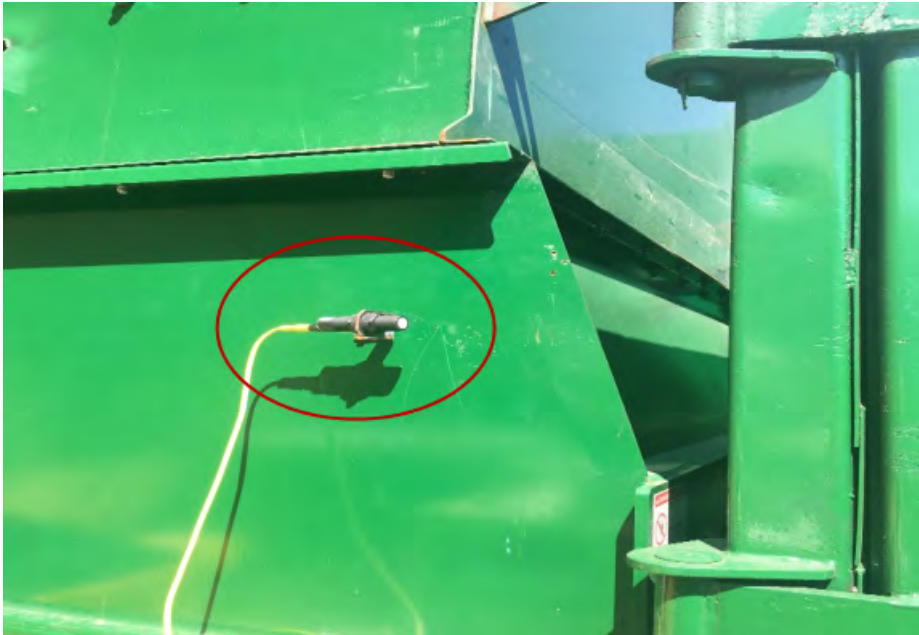

Figure 2: If the Light Curtain Reset amber push button is illuminated, depress the push button to reset the light curtains.



# Electric Container Dumper Operation

## AUTOMATIC OPERATION TROUBLESHOOTING GUIDE (CONTINUED)

If the illuminated push button does not reset, verify that there is nothing blocking the path of the light curtain. If the light curtain path is clear, inspect the lights located at the top of each light curtain.





# Electric Container Dumper

## Operation

### AUTOMATIC OPERATION TROUBLESHOOTING GUIDE (CONTINUED)

Check the status of each light located on the light curtain to verify light curtain function and alignment.

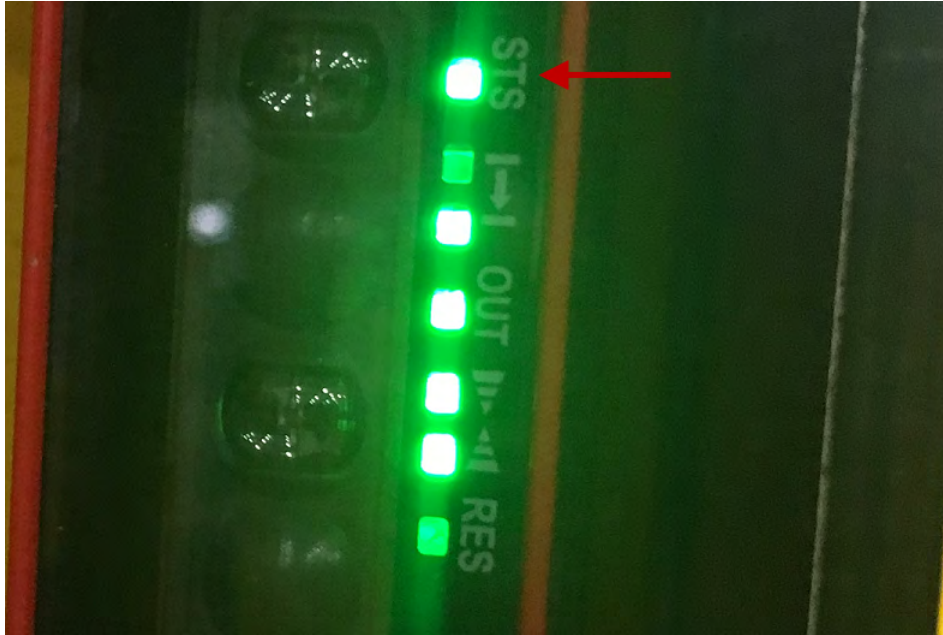

1. STS light should be green. This indicates that the light curtain has power and the system is okay. If the STS light is solid red or blinking green or red call Marathon Technical Service 877-258-1105.

# Electric Container Dumper Operation

## AUTOMATIC OPERATION TROUBLESHOOTING GUIDE (CONTINUED)

- 2. The next two lights indicate if the curtain is a transmitter or a receiver. If the top one is solid green then you are looking at the Transmitter. If the bottom one is solid green you are looking at the Receiver. If one of these two lights is blinking call Marathon Technical Service 877-258-1105.



- 3. OUT light will only be illuminated on the receiver and should be solid green. This light will not function on the transmitter. If this light is illuminated red call Marathon Technical Service 877-258-1105.



## AUTOMATIC OPERATION TROUBLESHOOTING GUIDE (CONTINUED)

4. The regional light intensity level 1 light indicates the status of the top half of the light curtain. If the light is solid green, then that half of the light curtain is OK. If the light is blinking green then the bottom half of the light curtain is reaching its function zone limit, and should be realigned. If this light is off then something is blocking the function zone or it is out of alignment beyond its function zone, and must be realigned.



5. The regional light intensity level 2 light indicates the status of the bottom half of the light curtain. If the light is solid green, then that half of the light curtain is OK. If the light is blinking green then the top half of the light curtain is reaching its function zone limit, and should be realigned. If this light is off then something is blocking the function zone or it is out of alignment beyond its function zone, and must be realigned.





# Electric Container Dumper Operation

## AUTOMATIC OPERATION TROUBLESHOOTING GUIDE (CONTINUED)

6. RES light indicates the start function. This light should be off to start the cart dumper. The Ok light will be red once the light curtain is tripped until clear. Once the bottom light is amber it can be reset.



**STEP THREE** - Push cart onto dumper. This will break the light curtain causing the amber, Light Curtain Reset, light on the dumper control pendant to illuminate.

**STEP FOUR** - Reset the light curtain by pushing in on the, amber, Light Curtain Reset, illuminated push-button until the light turns off. If the light does not go off refer back to Figure 2 to reset the light curtain.

**STEP FIVE** - Place the Dumper Auto/Manual selector switch in the Auto position.





# Electric Container Dumper Operation

## AUTOMATIC OPERATION TROUBLESHOOTING GUIDE (CONTINUED)

**STEP SIX** - Choose one or two cycles for the dumper to make by setting the Dumper Cycle selector switch. If two cycles are selected, the dumper will move to fully up position and then move partially down before going back to the fully up position. The dumper will lower when the second cycle is complete. If one cycle is selected, the dumper will move to the fully up position and then back to the down position.



# Electric Container Dumper Operation

## AUTOMATIC OPERATION TROUBLESHOOTING GUIDE (CONTINUED)

**STEP SEVEN** - Press the Auto Cycle push button and hold for 5 seconds to start. The dumper will make one or two cycles depending on the setting of the of the Dumper Cycle selector switch. (Note: If the dumper cycle is interrupted by breaking the light curtain during an auto cycle, the auger and the dumper will be taken out of automatic and stop. The Dumper Auto/ Manual selector switch must be turned to manual and the dumper lowered to the full down position using the Up/ Down selector switch before the unit can be put back in auto.



**STEP EIGHT** - The dumper will stop lifting when the up-proximity switch is actuated. After a short pause the dumper will lower. The dumper will stop lowering when the down proximity switch is actuated.

# Electric Container Dumper Operation

## AUTOMATIC OPERATION TROUBLESHOOTING GUIDE (CONTINUED)

**STEP NINE** - When the auto cycle is completed, the cart can be removed from the dumper.

If the compactor drops out of auto mode during a cycle check the Compactor Status indicator on the touchscreen.

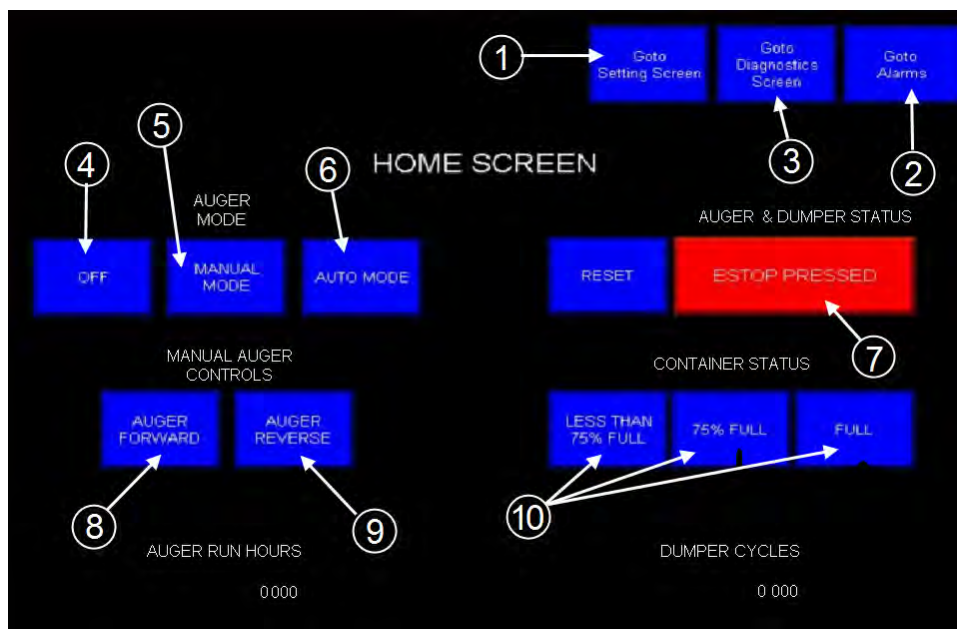

The following faults could be present:

1. E-STOP PRESSED - If this fault is indicated refer to Figure 1 to reset E-stop circuit.
2. BOTH MOTORS DID NOT START - If this fault is indicated call Marathon Technical Service 877-258-1105.
3. REVERSING STARTER DID NOT CHANGE STATE - If this fault is indicated call Marathon Technical Service 877-258-1105.
4. PHOTOCCELL BLOCKED AUTO SHUTDOWN - If this fault is indicated check the lower photocell located in the hopper to see if it is blocked. If the photocell is not blocked and the fault will not clear call Marathon Technical Service 877-258-1105.
5. MAX AMP COUNT REACHED - If this fault is indicated call Marathon Technical Service 877-258-1105.
6. START PUSH BUTTON FAULT - If this fault is indicated call Marathon Technical Service 877-258-1105.
7. LIGHT CURTAIN TRIPPED - If this fault is indicated refer to Figure 2 to reset the light curtains.
8. MULTIPLE FAULTS - If this fault is indicated you have multiple system faults. Begin at STEP ONE of this guide to eliminate each fault until Compactor OK status is achieved.
9. DUMPER MOVED AFTER SHUTDOWN CHECK MOTOR BRAKE - If this fault is indicated refer to your manual on PG 31 for motor brake inspection instructions.

**INTENTIONALLY LEFT BLANK**

# **SECTION 4**

# **SERVICE**

**CONTACT INFORMATION**



Technical Service and Warranty:

**877-258-1105**

Parts:

**800-528-5308**

For parts visit our eCommerce Marketplace at [www.mecomerchant.com](http://www.mecomerchant.com).

If you do not have a user name and password, contact our Parts Department and they will assist with your registration.

**Normal Business Hours:**

**Monday-Friday            8:00am - 5:00pm**

**(Central Standard Time)**

## LOCK-OUT & TAG-OUT INSTRUCTIONS

### DANGER



Before servicing dumper, be sure that all sources of energy have been shut off, all potential hazards have been eliminated, and the dumper is locked-out and tagged-out in accordance with OSHA and ANSI requirements.

The specific Lock-Out and Tag-Out instructions may vary from company to company (i.e. multiple locks may be required, or other machinery may need to be locked-out and tagged-out). The following instructions are provided as minimum guidelines.

## INSTRUCTIONS

1. Notify all affected employees that servicing, or maintenance is required on the dumper and that the dumper must be shut down and locked out to perform the servicing or maintenance.
2. Perform a hazard assessment;
  - a. The authorized employee shall refer to the company procedure to identify the type and magnitude of the energy that the dumper utilizes, shall understand the hazards of the energy, and shall know the methods to control the energy.
3. Wear proper personal protective equipment.
4. If dumper is operating, it must be shut down by the normal stopping procedure.
5. De-activate the energy isolating device(s) so that dumper is isolated from the energy source(s).
  - a. Shut down all power sources.
  - b. Move the main disconnect lever to the OFF position.
6. Lockout the energy isolating device(s) with assigned individual lock(s).
  - a. Padlock the disconnect lever with a keyed padlock and take the key with you.
  - b. Along with the padlock, place an appropriate, highly visible, warning tag on the disconnect lever. The tag should provide a warning such as:  
“Danger: Do not operate equipment. Person working on equipment.” or  
“Warning: Do not energize without the permission of \_\_\_\_\_.”
  - c. Place forks/tilt truck box in the fully down position as not to be subjected to possible free fall. Personnel should never occupy the space below an elevated load.
7. After locking and tagging the dumper, ensure that the dumper is disconnected from the energy source by first checking that no personnel are exposed, then verify the isolation of the equipment by operating the push button or other normal operating control(s) or by testing to make certain the equipment will not operate. Try to start and operate the dumper (as outlined in the Operating Instructions) to make sure the Lock-Out and Tag-Out is effective. If the Lock-Out and Tag-Out is effective, remove the key from the key switch and take it with you.
9. Before servicing dumper perform hazard assessment for confined space requirements (hazardous fumes, dust, toxic material, or other hazards) per the OSHA confined space standard.
10. The dumper is now locked out.

# Electric Container Dumper Service

## LOCK-OUT & TAG-OUT INSTRUCTIONS (CONTINUED)

### RESTORING SERVICE

When the servicing or maintenance is completed, and the dumper is ready to return to normal operating condition, the following steps shall be taken:

1. Check the dumper and the immediate area around the dumper to ensure that nonessential items have been removed and that the dumper components, guards and covers are operationally intact.
2. Check the work area to ensure that all employees have been safely positioned or removed from any hazardous area.
3. Verify that the controls are in neutral.
4. Remove the lockout devices and re-energize the dumper.
5. Notify affected employees that the servicing or maintenance is completed, and the dumper is ready for use.
6. Reassess area to determine all hazards are protected.



### PERIODIC MAINTENANCE

#### **WARNING**

---

Never perform any maintenance on any part of the dumper until the dumper has been locked out and tagged out.

---

#### **200 Hours of Operation**

- Check for any unsafe conditions in the dumper area
- Check flexible conduit and cables for chafing, rubbing, or other deterioration and damage.
- Check oil level in gearbox. Level should be to the top of the sight gauge.
- Check limit switches for functionality.
- Check position transducer cable for chafing, rubbing, or deterioration and damage.
- Ensure the brake on the motor is engaged.
- Check Automatic greaser level.

#### **600 Hours of Operation**

- Check functional operation of controls.
- Check operation of access gate / light curtain.
- Check motor brake for proper function.

#### **2000 Hours of Operation**

- Lubricate electric motor bearings annually per the manufacturer's instructions.
- Change the gearbox fluid. Fill to the top of the sight glass. See Recommended Gearbox Oil  12

# Electric Container Dumper

## Service

**PERIODIC MAINTENANCE (CONTINUED)**

MAINTENANCE SCHEDULE				
200 HOURS				
CHECK FOR UNSAFE CONDITIONS	CHECK FLEXIBLE CONDUIT	CHECK GEARBOX OIL LEVEL	CHECK PROXIMITY SWITCHES	MOTOR BRAKE ENGAGED

MAINTENANCE SCHEDULE				
600 HOURS			2000 HOURS	
CHECK CONTROLS	CHECK OPERATION OF ACCESS DEVICE	CHECK MOTOR BRAKE FOR FUNCTIONALITY	LUBRICATE MOTOR	CHANGE GEARBOX FLUID

## BRAKE MOTOR OPERATION

### **⚠ DANGER**

Never disengage the brake with anyone inside the dumper area.

### **⚠ WARNING**

Never perform any maintenance on any part of the dumper until the dumper has been locked out and tagged out.

Do not remove brake motor cover or guard unless you intend to disengage or adjust the brake. Immediately replace the brake motor guard and cover, once brake motor maintenance has been completed. The only time the brake on the motor should be disengaged is to lower the dumper in the event of a failure. Failures could be caused by a power outage, malfunctioning controls, motor failure, etc. Never leave the break in the disengaged position. Releasing the motor brake:

1. Remove the brake motor cover.

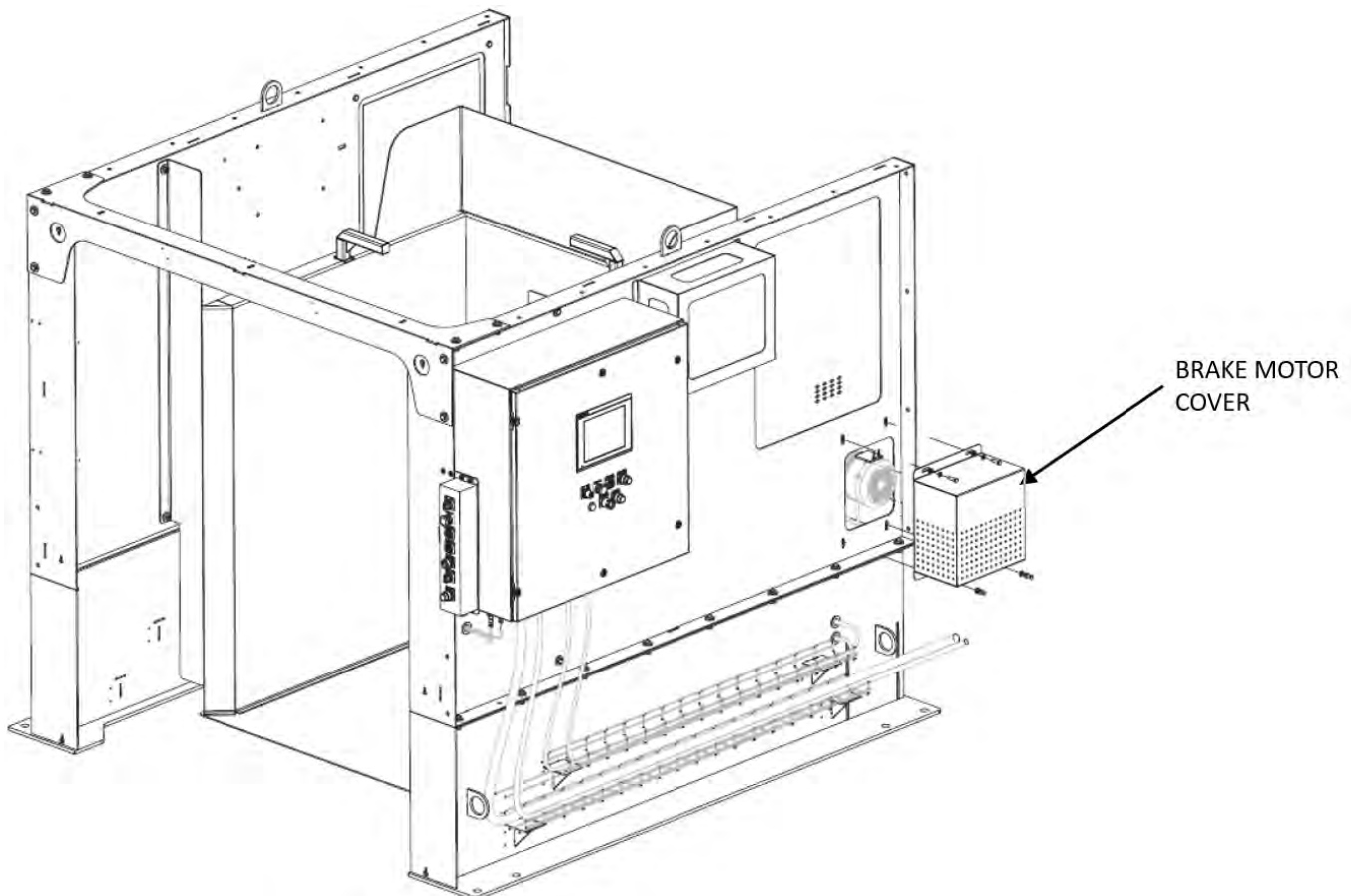

# Electric Container Dumper Service

## BRAKE MOTOR OPERATION (CONTINUED)

2. Remove the brake motor guard.

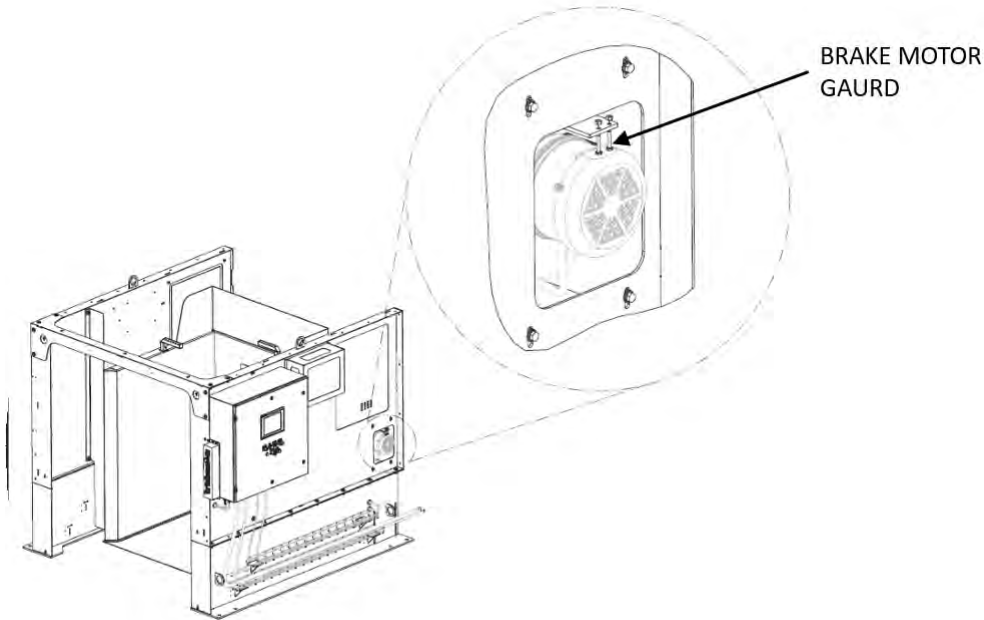

3. Push the brake lever towards the disengaged position. Note that the brake can be partially disengaged to slowly lower the dumper. Never fully disengage the brake while the dumper is in an elevated position.

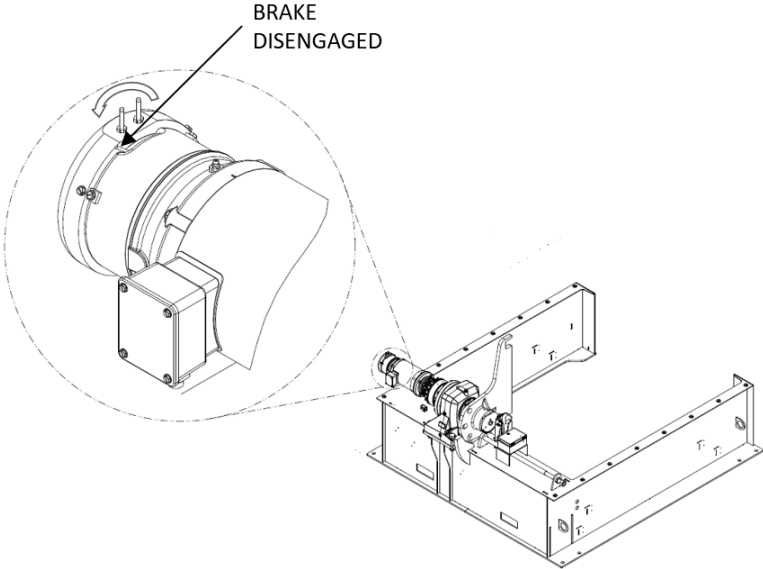

## BRAKE MOTOR OPERATION (CONTINUED)

4. Return the brake lever to the engaged position.

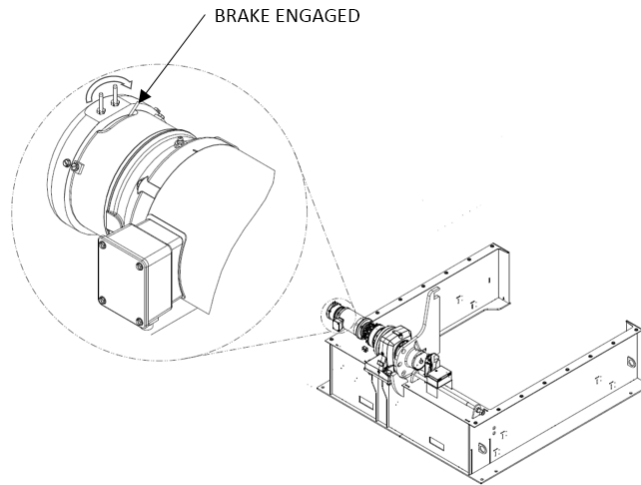

5. Re-install the brake manual release guard. Note the brake manual release guard orientation.
6. Re-install the brake motor cover.

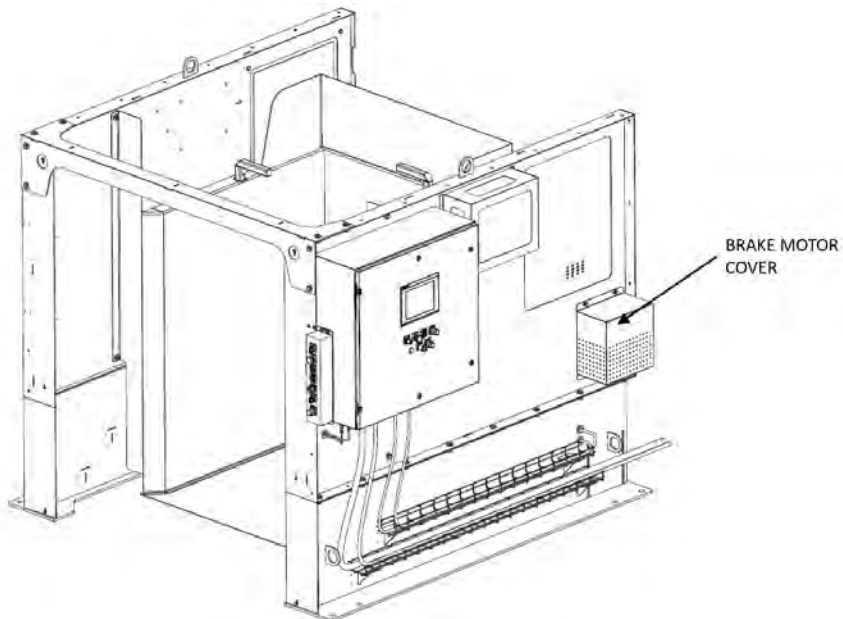

## MAINTENANCE/HOUSEKEEPING STOP

### **WARNING**

Never perform any maintenance on any part of the dumper until the dumper has been locked out and tagged out.

### **WARNING**

Never enter dumper area to perform housekeeping without first engaging the Maintenance/Housekeeping stop.

### To engage the maintenance stop:

1. Run the dumper all the way up to the 135° position.
2. Depress the red E-stop button.
3. Fully engage maintenance stop using an impact wrench from outside of the dumper safety cage.

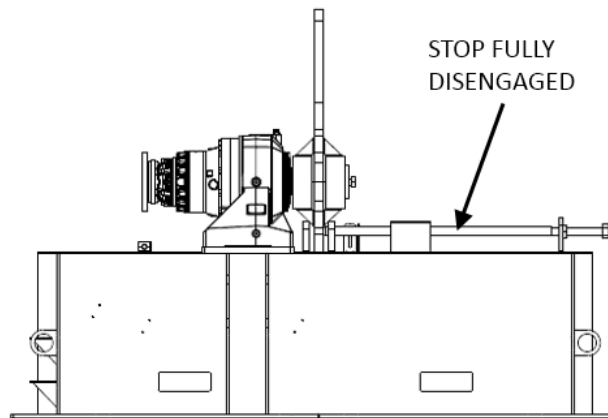

4. Follow the regular lock-out tag-out procedure excluding step 6C.
5. Once work is complete. Ensure the dumper area is clear then fully disengage the maintenance stop from outside of the dumper cage.

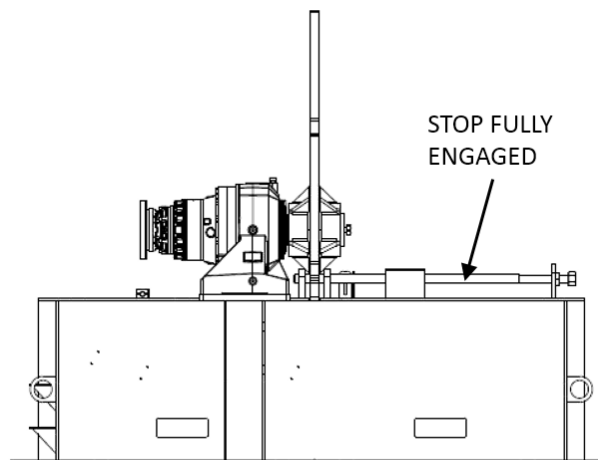

6. Restore power.
7. Follow standard start-up procedure and return the dumper to the fully lowered position.

## PRINCIPLES OF OPERATION

### Dumper with Sustained-Manual-Pressure Controls Operating Characteristics

When the key is inserted into the key switch, turned clockwise to the ON position, a contact is made that energizes the controls. Once all amber reset lights are depressed and no longer illuminated and dumper is reset to OK, the dumper is now ready to operate. With the auto/manual switch in the manual position, the dumper may be operated manually by turning the UP/DOWN selector switch in the desired direction. The dumper can freely move from the down position of 0 degrees to the up position of 135 degrees. The full down position of 0 degrees, and full up position of 135 degrees have proximity switches in place that are factory set. The EMERGENCY STOP button will shut the dumper down when pressed by removing power to the controls. Always remove the key from the key switch when the dumper is not in use.

### Dumper with Automatic Control Operating Characteristics

When the key is inserted into the key switch, turned clockwise to the ON position, a contact is made that energizes the controls. Once all amber reset lights are depressed and no longer illuminated and dumper is reset to OK, the dumper is now ready to operate. Place the compactor into auto by pressing and holding the auto button on the HMI. An audible alarm will sound for 5 seconds, and a timer will count for 20 seconds before the compactor starts. When the auto/manual selector switch is in the auto position, the dumper may be operated by depressing the Green auto cycle start pushbutton. This starts the electric motor which rotates the dumper. The dumper can freely move from the down position of 0 degrees to the up position of 135 degrees. Full down position of 0 degrees, and full up position of 135 degrees have proximity switches in place that are factory set. The dumper cycle 1 or 2 selector switch allows you to run one or two cycles. With 1 cycle selected the dumper will automatically rotate from the 0 degree full down position to the 135 degrees full up position, and return to the 0 degree position. With the 2 cycle selected the dumper will automatically rotate from 0 degree full down position to the 135 degree full up position. The dumper will then rotate down to the 45 degree position, then return to the 135 degree position before returning to the full down position. An audible alarm will sound while dumper is operating in automatic mode. The EMERGENCY STOP button will shut the dumper down when pressed by removing power to the controls. Always remove the key from the key switch when the dumper is not in use.

Note: Refer to RamJet® Stationary Auger Compactor Operation, Service and Installation Manual for information related to the integrated AST-440 Stationary Auger Compactor (if equipped).

# Electric Container Dumper Service

## ELECTRICAL CHARTS

FUSES AND CIRCUIT BREAKERS					
Three Phase					
MOTOR SIZE	VAC	FULL LOAD AMP	DUAL ELEMENT FUSE MAX.SIZE	CIRCUIT BREAKER MAX.SIZE	SERVICE DISCONNECT AMP.
1 1/2 HP	208	6.6	15	20	30
	230	6.0	15	15	30
	460	3.0	6	15	30
	575	2.4	6	15	30
3 HP	208	10.6	15	20	30
	230	9.6	15	20	30
	460	4.8	10	15	30
	575	3.9	10	15	30

WIRE SIZES				
Three Phase	THW Copper 75°C (165°F)			
MOTOR SIZE	VOLTAGE	LENGTH		
		TO 100'	TO 200'	TO 300'
1 1/2 HP	208	12	12	10
	230	12	12	12
	460	12	12	12
	575	12	12	12
3 HP	208	10	8	6
	230	12	10	8
	460	12	12	12
	575	12	12	12



# Electric Container Dumper Service

## ELECTRICAL SCHEMATIC (DUMPER WITH INTEGRATED AST-440)

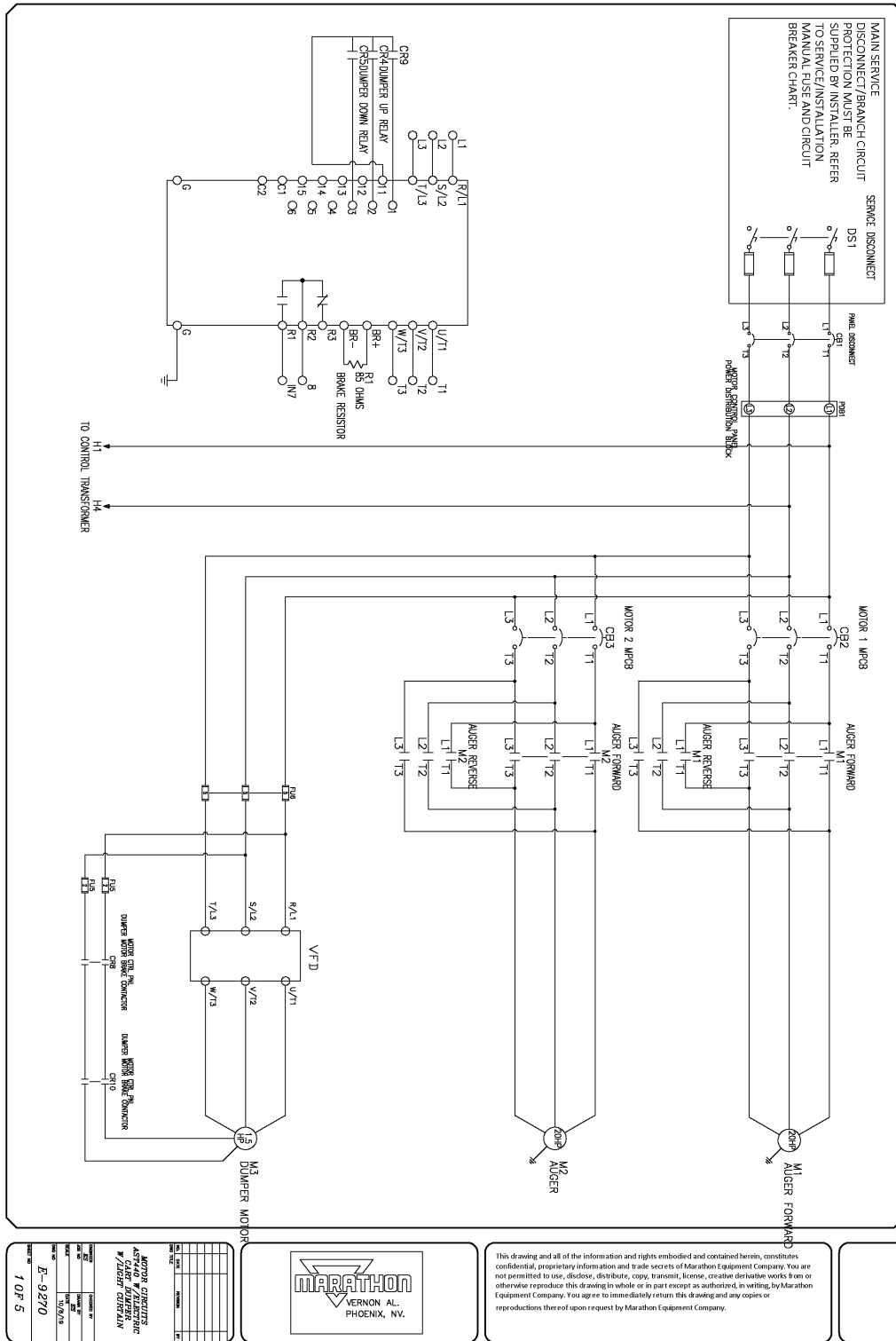

# Electric Container Dumper Service

## ELECTRICAL SCHEMATIC (DUMPER WITH INTEGRATED AST-440) (CONTINUED)

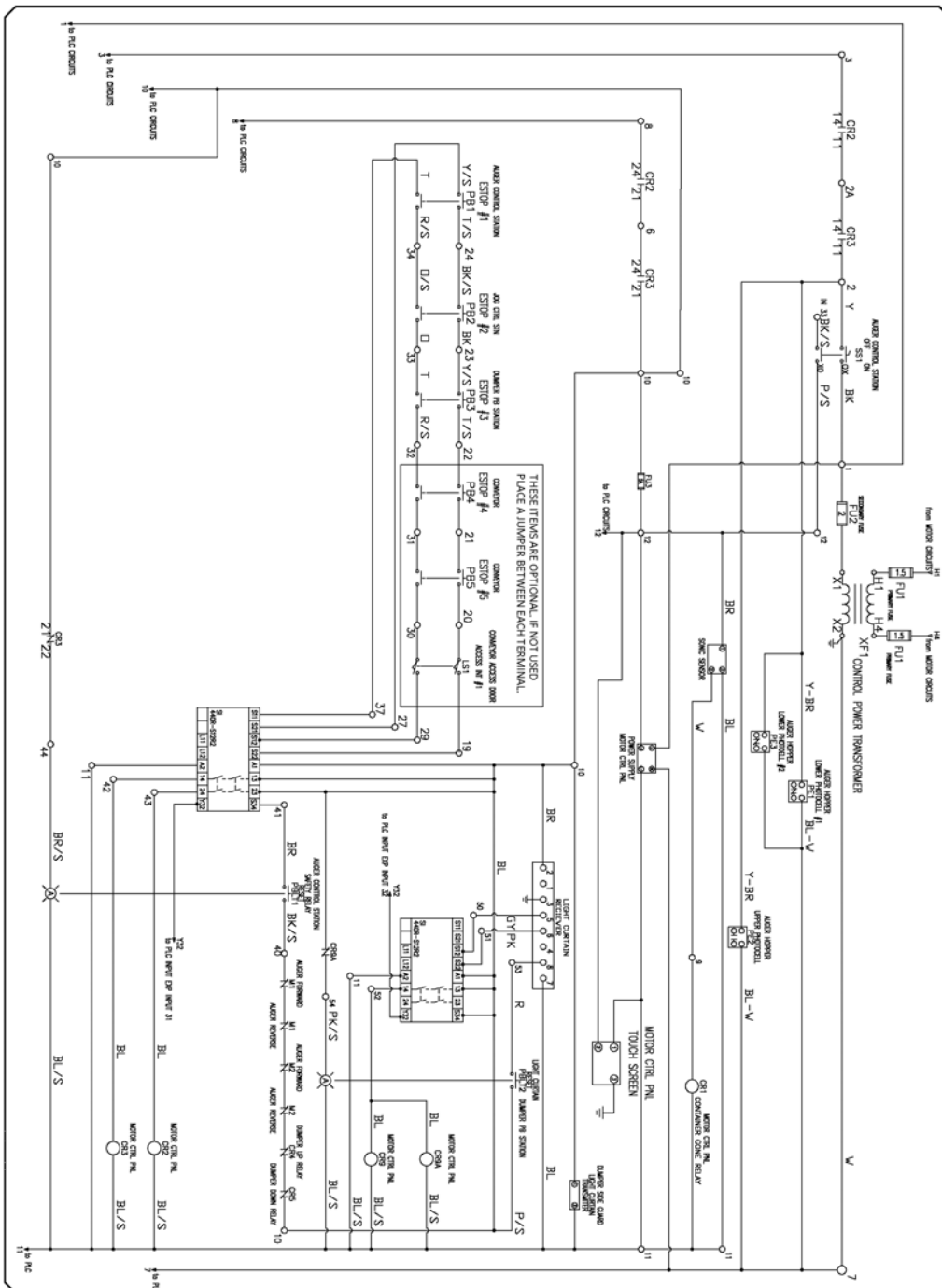

THESE ITEMS ARE OPTIONAL, IF NOT USED PLACE A JUMPER BETWEEN EACH TERMINAL.

ACKER CONTROL STATION: ESTOP #1 Y/S PB1 T/S 24 BK/S  
 DUMPER IN STATION: ESTOP #2 BK 23 Y/S PB3 T/S 22  
 DUMPER OUT STATION: ESTOP #3 P/B4 21 ESTOP #5 P/S 20 ACCESS IN P/1  
 Acker Control Station: 19, 20, 21, 22, 23, 24, 25, 26, 27, 28, 29, 30, 31, 32, 33, 34, 35, 36, 37, 38, 39, 40, 41, 42, 43, 44, 45, 46, 47, 48, 49, 50, 51, 52, 53, 54, 55, 56, 57, 58, 59, 60, 61, 62, 63, 64, 65, 66, 67, 68, 69, 70, 71, 72, 73, 74, 75, 76, 77, 78, 79, 80, 81, 82, 83, 84, 85, 86, 87, 88, 89, 90, 91, 92, 93, 94, 95, 96, 97, 98, 99, 100, 101, 102, 103, 104, 105, 106, 107, 108, 109, 110, 111, 112, 113, 114, 115, 116, 117, 118, 119, 120, 121, 122, 123, 124, 125, 126, 127, 128, 129, 130, 131, 132, 133, 134, 135, 136, 137, 138, 139, 140, 141, 142, 143, 144, 145, 146, 147, 148, 149, 150, 151, 152, 153, 154, 155, 156, 157, 158, 159, 160, 161, 162, 163, 164, 165, 166, 167, 168, 169, 170, 171, 172, 173, 174, 175, 176, 177, 178, 179, 180, 181, 182, 183, 184, 185, 186, 187, 188, 189, 190, 191, 192, 193, 194, 195, 196, 197, 198, 199, 200, 201, 202, 203, 204, 205, 206, 207, 208, 209, 210, 211, 212, 213, 214, 215, 216, 217, 218, 219, 220, 221, 222, 223, 224, 225, 226, 227, 228, 229, 230, 231, 232, 233, 234, 235, 236, 237, 238, 239, 240, 241, 242, 243, 244, 245, 246, 247, 248, 249, 250, 251, 252, 253, 254, 255, 256, 257, 258, 259, 260, 261, 262, 263, 264, 265, 266, 267, 268, 269, 270, 271, 272, 273, 274, 275, 276, 277, 278, 279, 280, 281, 282, 283, 284, 285, 286, 287, 288, 289, 290, 291, 292, 293, 294, 295, 296, 297, 298, 299, 300, 301, 302, 303, 304, 305, 306, 307, 308, 309, 310, 311, 312, 313, 314, 315, 316, 317, 318, 319, 320, 321, 322, 323, 324, 325, 326, 327, 328, 329, 330, 331, 332, 333, 334, 335, 336, 337, 338, 339, 340, 341, 342, 343, 344, 345, 346, 347, 348, 349, 350, 351, 352, 353, 354, 355, 356, 357, 358, 359, 360, 361, 362, 363, 364, 365, 366, 367, 368, 369, 370, 371, 372, 373, 374, 375, 376, 377, 378, 379, 380, 381, 382, 383, 384, 385, 386, 387, 388, 389, 390, 391, 392, 393, 394, 395, 396, 397, 398, 399, 400, 401, 402, 403, 404, 405, 406, 407, 408, 409, 410, 411, 412, 413, 414, 415, 416, 417, 418, 419, 420, 421, 422, 423, 424, 425, 426, 427, 428, 429, 430, 431, 432, 433, 434, 435, 436, 437, 438, 439, 440, 441, 442, 443, 444, 445, 446, 447, 448, 449, 450, 451, 452, 453, 454, 455, 456, 457, 458, 459, 460, 461, 462, 463, 464, 465, 466, 467, 468, 469, 470, 471, 472, 473, 474, 475, 476, 477, 478, 479, 480, 481, 482, 483, 484, 485, 486, 487, 488, 489, 490, 491, 492, 493, 494, 495, 496, 497, 498, 499, 500, 501, 502, 503, 504, 505, 506, 507, 508, 509, 510, 511, 512, 513, 514, 515, 516, 517, 518, 519, 520, 521, 522, 523, 524, 525, 526, 527, 528, 529, 530, 531, 532, 533, 534, 535, 536, 537, 538, 539, 540, 541, 542, 543, 544, 545, 546, 547, 548, 549, 550, 551, 552, 553, 554, 555, 556, 557, 558, 559, 560, 561, 562, 563, 564, 565, 566, 567, 568, 569, 570, 571, 572, 573, 574, 575, 576, 577, 578, 579, 580, 581, 582, 583, 584, 585, 586, 587, 588, 589, 590, 591, 592, 593, 594, 595, 596, 597, 598, 599, 600, 601, 602, 603, 604, 605, 606, 607, 608, 609, 610, 611, 612, 613, 614, 615, 616, 617, 618, 619, 620, 621, 622, 623, 624, 625, 626, 627, 628, 629, 630, 631, 632, 633, 634, 635, 636, 637, 638, 639, 640, 641, 642, 643, 644, 645, 646, 647, 648, 649, 650, 651, 652, 653, 654, 655, 656, 657, 658, 659, 660, 661, 662, 663, 664, 665, 666, 667, 668, 669, 670, 671, 672, 673, 674, 675, 676, 677, 678, 679, 680, 681, 682, 683, 684, 685, 686, 687, 688, 689, 690, 691, 692, 693, 694, 695, 696, 697, 698, 699, 700, 701, 702, 703, 704, 705, 706, 707, 708, 709, 710, 711, 712, 713, 714, 715, 716, 717, 718, 719, 720, 721, 722, 723, 724, 725, 726, 727, 728, 729, 730, 731, 732, 733, 734, 735, 736, 737, 738, 739, 740, 741, 742, 743, 744, 745, 746, 747, 748, 749, 750, 751, 752, 753, 754, 755, 756, 757, 758, 759, 760, 761, 762, 763, 764, 765, 766, 767, 768, 769, 770, 771, 772, 773, 774, 775, 776, 777, 778, 779, 780, 781, 782, 783, 784, 785, 786, 787, 788, 789, 790, 791, 792, 793, 794, 795, 796, 797, 798, 799, 800, 801, 802, 803, 804, 805, 806, 807, 808, 809, 810, 811, 812, 813, 814, 815, 816, 817, 818, 819, 820, 821, 822, 823, 824, 825, 826, 827, 828, 829, 830, 831, 832, 833, 834, 835, 836, 837, 838, 839, 840, 841, 842, 843, 844, 845, 846, 847, 848, 849, 850, 851, 852, 853, 854, 855, 856, 857, 858, 859, 860, 861, 862, 863, 864, 865, 866, 867, 868, 869, 870, 871, 872, 873, 874, 875, 876, 877, 878, 879, 880, 881, 882, 883, 884, 885, 886, 887, 888, 889, 890, 891, 892, 893, 894, 895, 896, 897, 898, 899, 900, 901, 902, 903, 904, 905, 906, 907, 908, 909, 910, 911, 912, 913, 914, 915, 916, 917, 918, 919, 920, 921, 922, 923, 924, 925, 926, 927, 928, 929, 930, 931, 932, 933, 934, 935, 936, 937, 938, 939, 940, 941, 942, 943, 944, 945, 946, 947, 948, 949, 950, 951, 952, 953, 954, 955, 956, 957, 958, 959, 960, 961, 962, 963, 964, 965, 966, 967, 968, 969, 970, 971, 972, 973, 974, 975, 976, 977, 978, 979, 980, 981, 982, 983, 984, 985, 986, 987, 988, 989, 990, 991, 992, 993, 994, 995, 996, 997, 998, 999, 1000.

REV	DATE	DESCRIPTION

DESIGNED BY: J. STONE  
 CHECKED BY: J. STONE  
 DATE: 10/01/21  
 2-9270  
 2 OF 5



This drawing and all of the information and rights embodied and contained herein, constitutes confidential, proprietary information and trade secrets of Marathon Equipment Company. You are not permitted to use, disclose, distribute, copy, transmit, license, create derivative works from or otherwise reproduce this drawing in whole or in part except as authorized, in writing, by Marathon Equipment Company. You agree to immediately return this drawing and any copies or reproductions thereof upon request by Marathon Equipment Company.

# Electric Container Dumper Service

## ELECTRICAL SCHEMATIC (DUMPER WITH INTEGRATED AST-440) (CONTINUED)

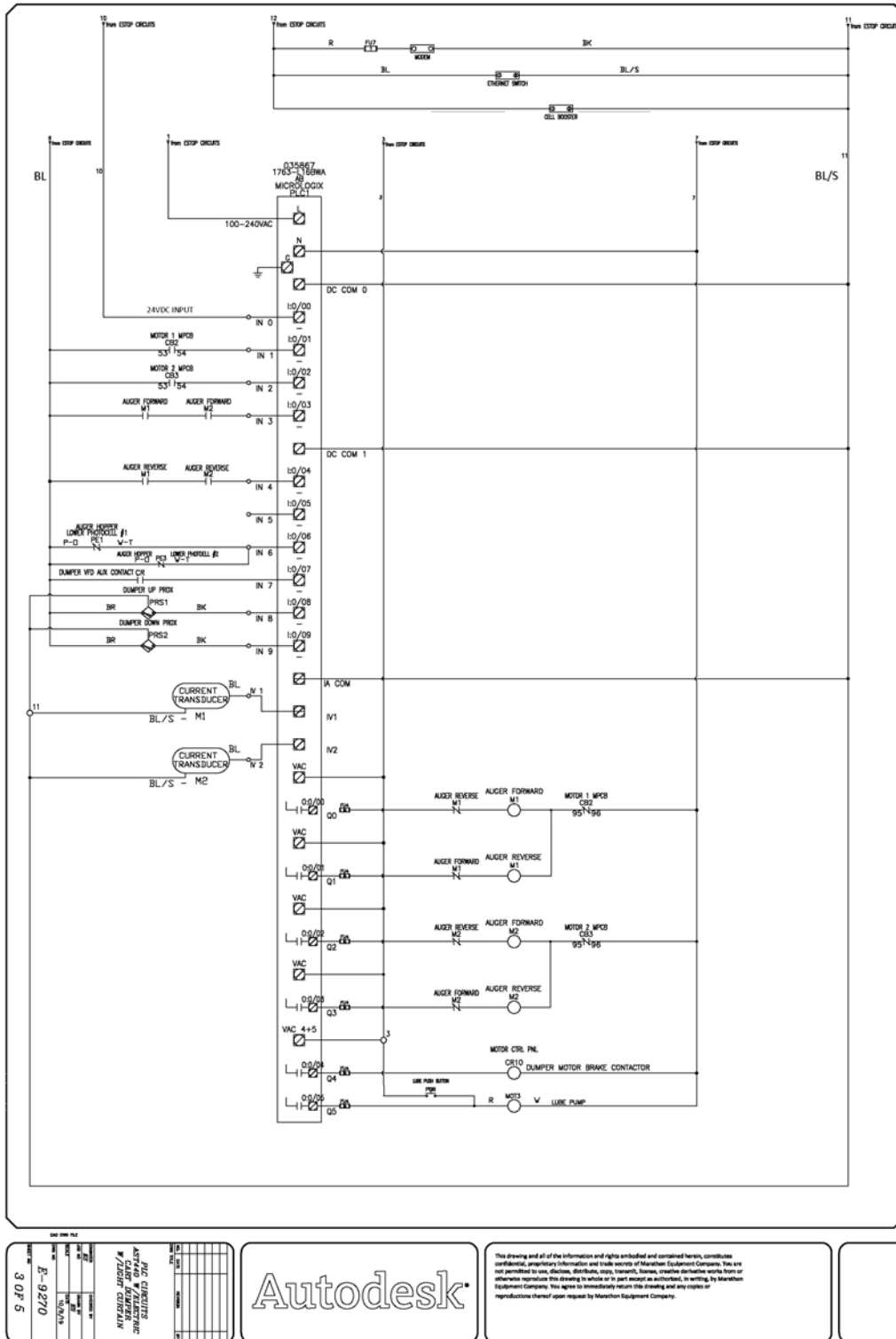

REV	DATE	BY	CHK	DESCRIPTION
1				
2				
3				
4				
5				

3 OF 5



This drawing and all of the information and rights embodied and contained herein, constitute confidential, proprietary information and trade secrets of Marathon Equipment Company. You are not permitted to use, disclose, distribute, copy, transfer, loan, create derivative works from or otherwise reproduce this drawing in whole or in part except as authorized, in writing, by Marathon Equipment Company. You agree to immediately return this drawing and any copies or reproductions thereof upon request by Marathon Equipment Company.

# Electric Container Dumper Service

## ELECTRICAL SCHEMATIC (DUMPER WITH INTEGRATED AST-440) (CONTINUED)

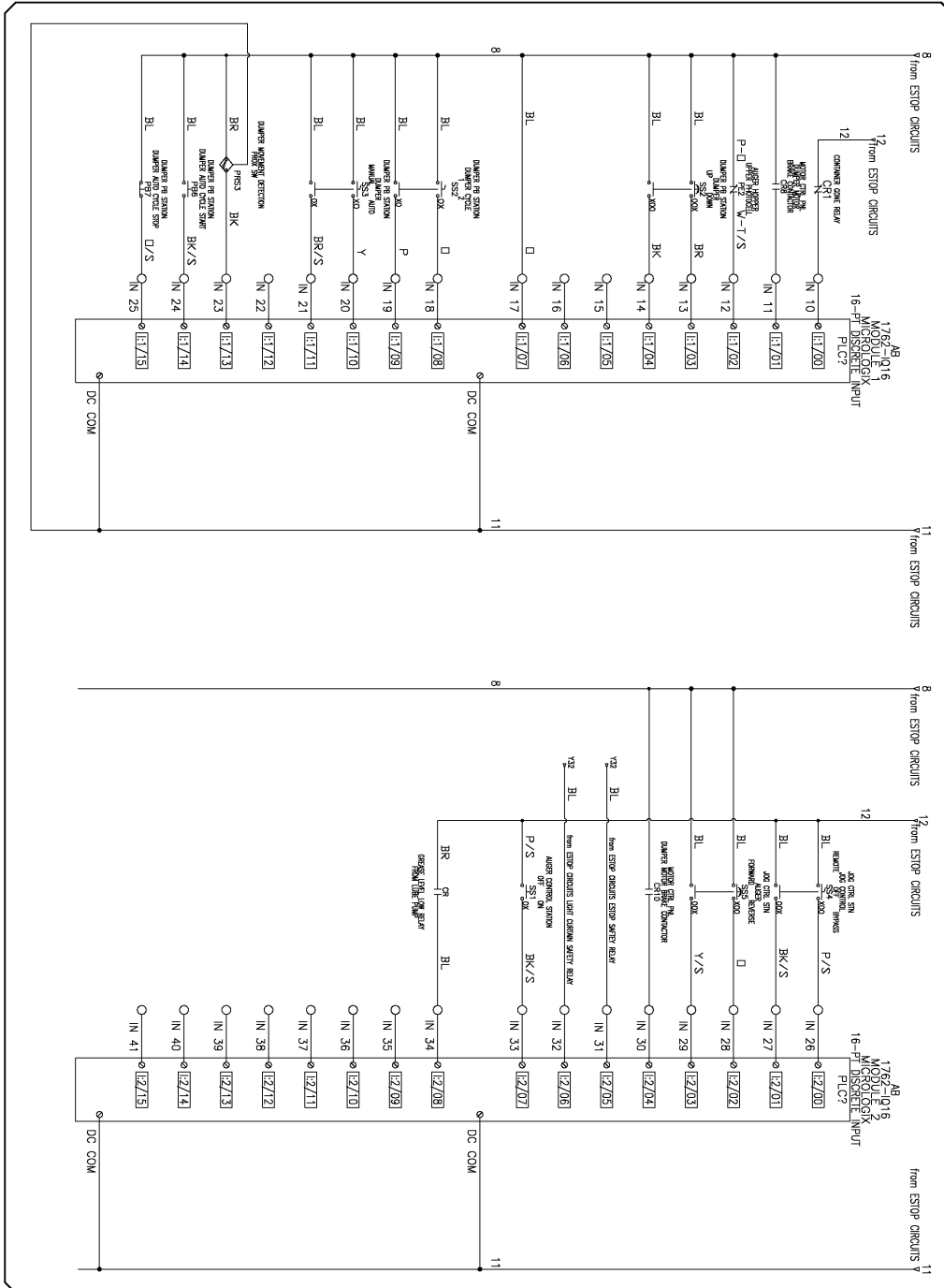

REV	DATE	DESCRIPTION
1		
2		
3		
4		
5		
6		
7		
8		
9		
10		
11		
12		
13		
14		
15		
16		
17		
18		
19		
20		
21		
22		
23		
24		
25		
26		
27		
28		
29		
30		
31		
32		
33		
34		
35		
36		
37		
38		
39		
40		
41		
42		
43		
44		
45		
46		
47		
48		
49		
50		
51		
52		
53		
54		
55		
56		
57		
58		
59		
60		
61		
62		
63		
64		
65		
66		
67		
68		
69		
70		
71		
72		
73		
74		
75		
76		
77		
78		
79		
80		
81		
82		
83		
84		
85		
86		
87		
88		
89		
90		
91		
92		
93		
94		
95		
96		
97		
98		
99		
100		
101		
102		
103		
104		
105		
106		
107		
108		
109		
110		
111		
112		
113		
114		
115		
116		
117		
118		
119		
120		
121		
122		
123		
124		
125		
126		
127		
128		
129		
130		
131		
132		
133		
134		
135		
136		
137		
138		
139		
140		
141		
142		
143		
144		
145		
146		
147		
148		
149		
150		
151		
152		
153		
154		
155		
156		
157		
158		
159		
160		
161		
162		
163		
164		
165		
166		
167		
168		
169		
170		
171		
172		
173		
174		
175		
176		
177		
178		
179		
180		
181		
182		
183		
184		
185		
186		
187		
188		
189		
190		
191		
192		
193		
194		
195		
196		
197		
198		
199		
200		
201		
202		
203		
204		
205		
206		
207		
208		
209		
210		
211		
212		
213		
214		
215		
216		
217		
218		
219		
220		
221		
222		
223		
224		
225		
226		
227		
228		
229		
230		
231		
232		
233		
234		
235		
236		
237		
238		
239		
240		
241		
242		
243		
244		
245		
246		
247		
248		
249		
250		
251		
252		
253		
254		
255		
256		
257		
258		
259		
260		
261		
262		
263		
264		
265		
266		
267		
268		
269		
270		
271		
272		
273		
274		
275		
276		
277		
278		
279		
280		
281		
282		
283		
284		
285		
286		
287		
288		
289		
290		
291		
292		
293		
294		
295		
296		
297		
298		
299		
300		



This drawing and all of the information and rights embodied and contained herein, constitutes confidential, proprietary information and trade secrets of Marathon Equipment Company. You are not permitted to use, disclose, distribute, copy, transmit, license, create derivative works from or otherwise reproduce this drawing in whole or in part except as authorized, in writing, by Marathon Equipment Company. You agree to immediately return this drawing and any copies or reproductions thereof upon request by Marathon Equipment Company.

# Electric Container Dumper Service

## ELECTRICAL SCHEMATIC (DUMPER WITH INTEGRATED AST-440) (CONTINUED)

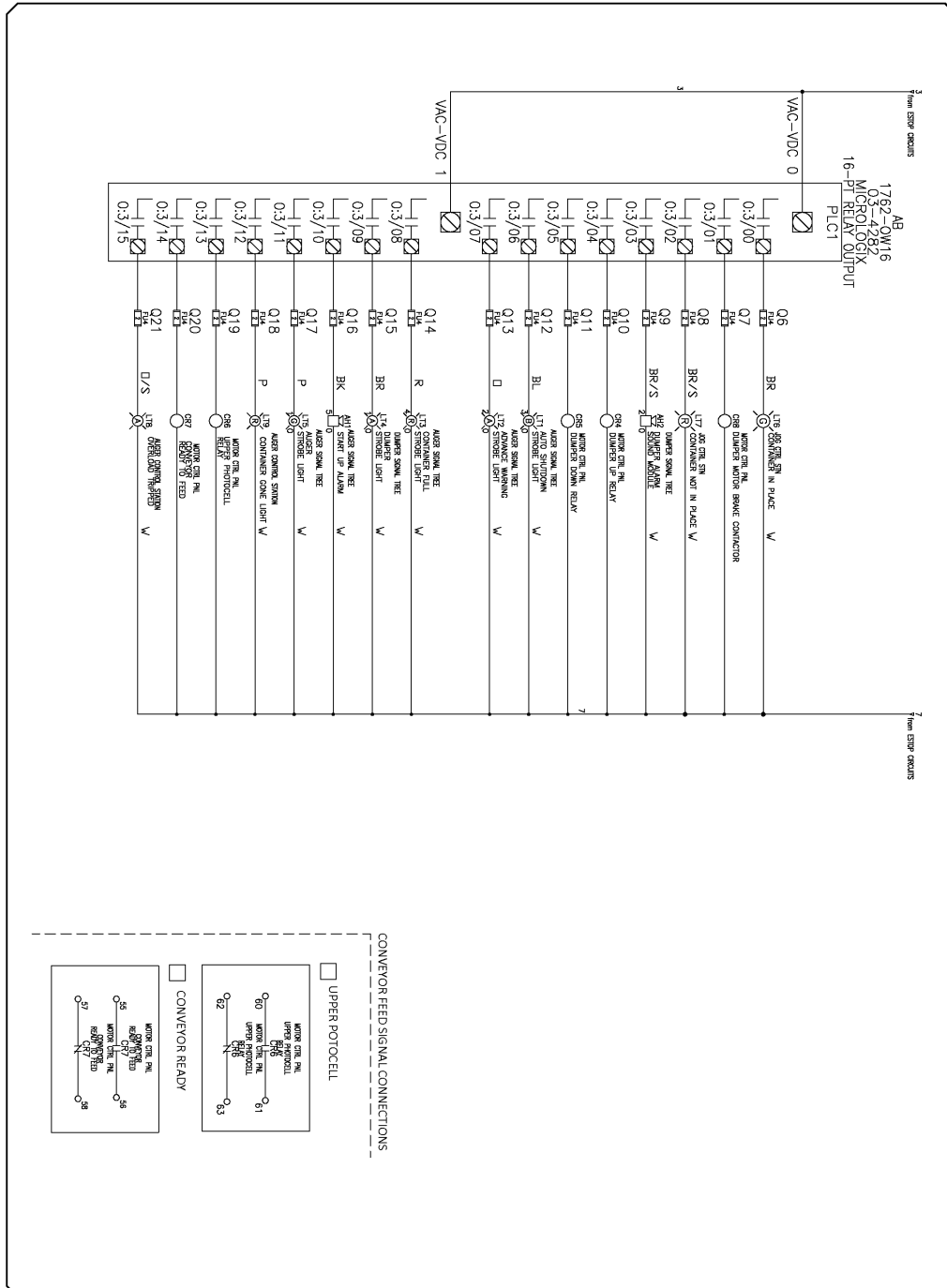

REV	DATE	DESCRIPTION
1		
2		
3		
4		
5		

QUOTE EXPANSION  
 ASP 410 W/ALTERNATE  
 V/ALICE GIBLIN  
 DATE 10/26/20  
 P-9270  
 5 OF 5



This drawing and all of the information and rights embodied and contained herein, constitutes confidential, proprietary information and trade secrets of Marathon Equipment Company. You are not permitted to use, disclose, distribute, copy, transmit, license, create derivative works from or otherwise reproduce this drawing in whole or in part except as authorized, in writing, by Marathon Equipment Company. You agree to immediately return this drawing and any copies or reproductions thereof upon request by Marathon Equipment Company.

# Electric Container Dumper Service

## ELECTRICAL SCHEMATIC STAND ALONE DUMPER

### E-2014 Motor and E-stop Circuits

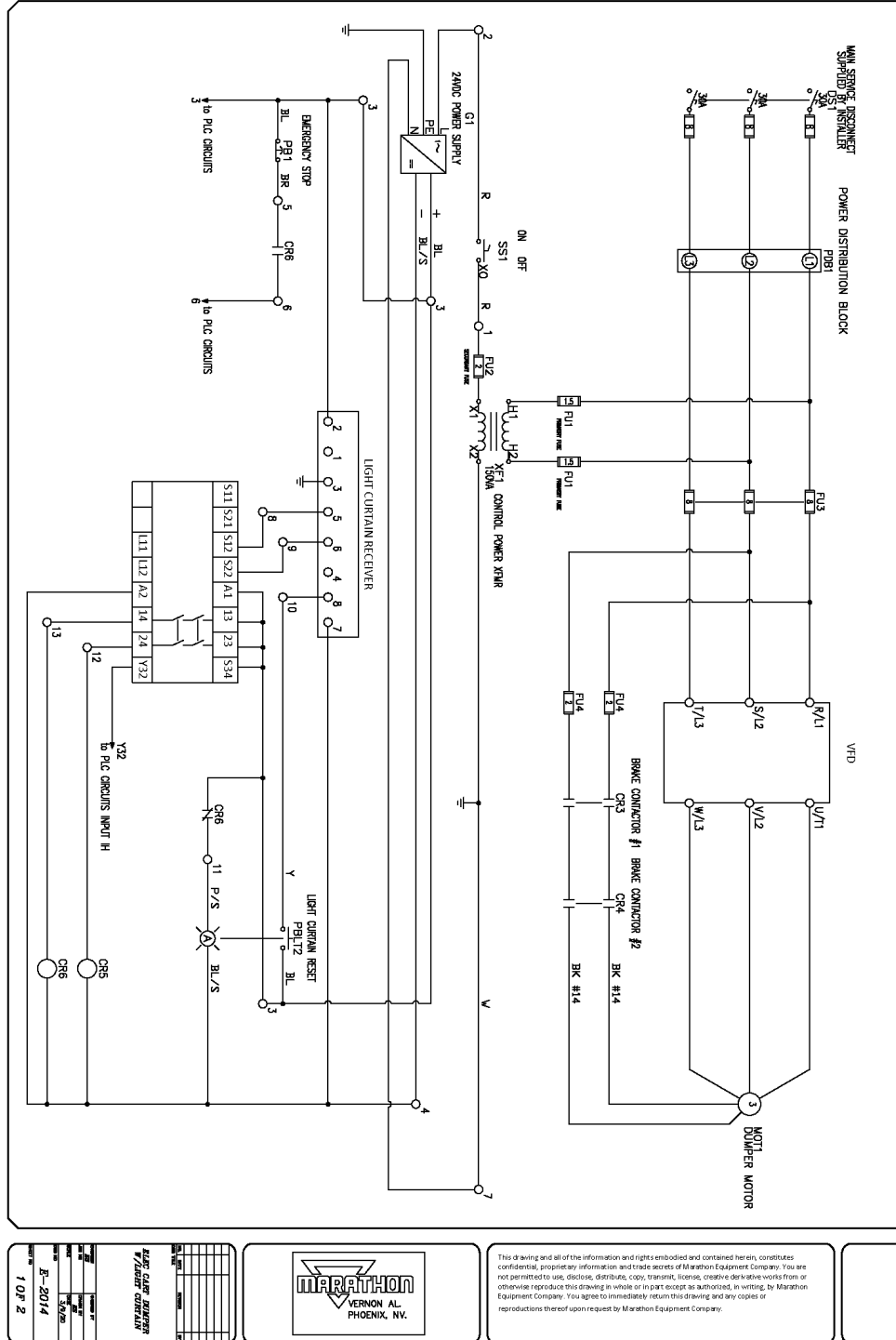

# Electric Container Dumper Service

## ELECTRICAL SCHEMATIC STAND ALONE DUMPER (CONTINUED)

### E-2014 PLC Circuits

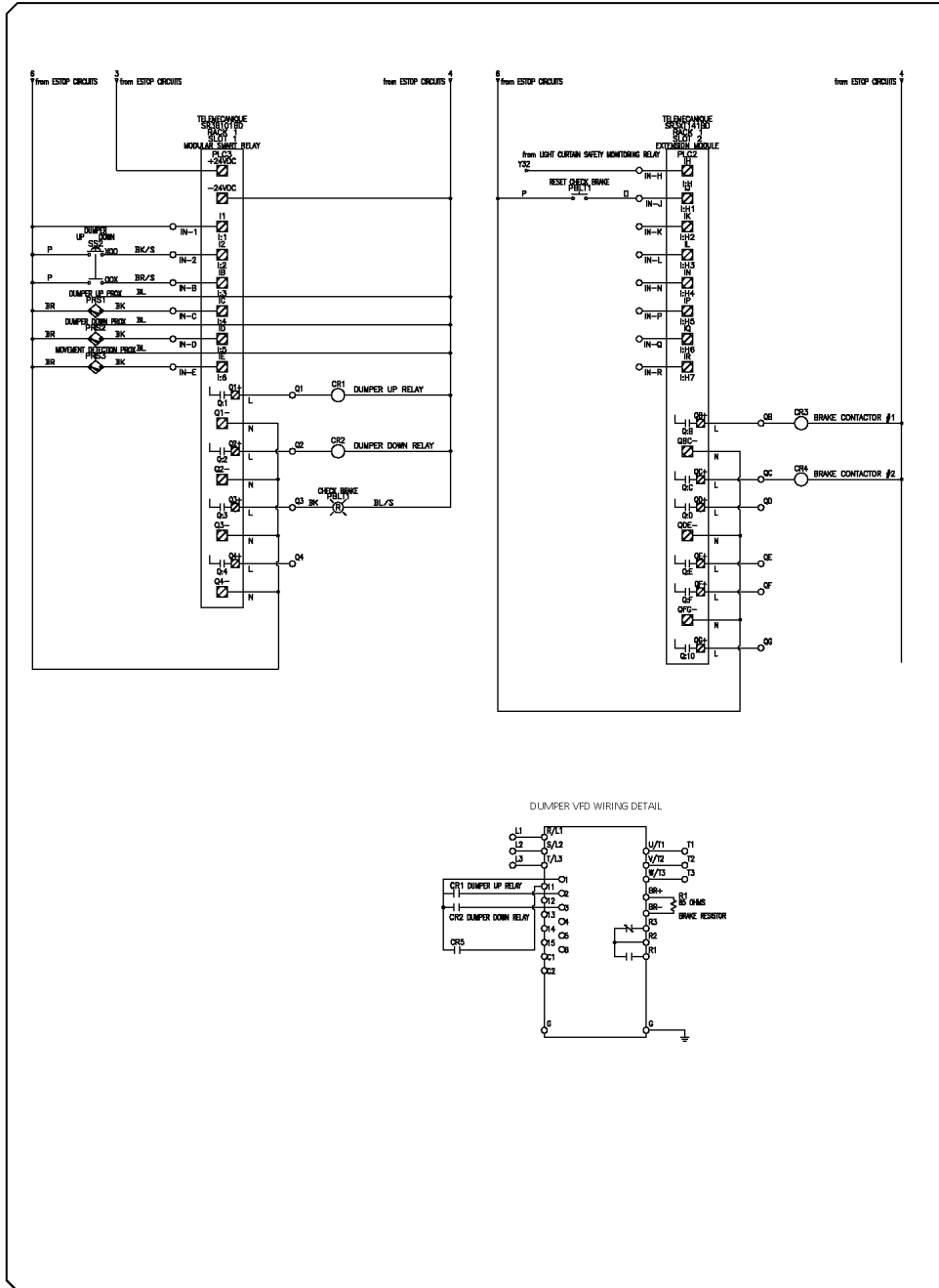

REV	DATE	BY	CHKD
1	11/14/14	WJ	WJ
2	01/14/15	WJ	WJ
3	01/14/15	WJ	WJ
4	01/14/15	WJ	WJ
5	01/14/15	WJ	WJ
6	01/14/15	WJ	WJ
7	01/14/15	WJ	WJ
8	01/14/15	WJ	WJ
9	01/14/15	WJ	WJ
10	01/14/15	WJ	WJ
11	01/14/15	WJ	WJ
12	01/14/15	WJ	WJ
13	01/14/15	WJ	WJ
14	01/14/15	WJ	WJ
15	01/14/15	WJ	WJ
16	01/14/15	WJ	WJ
17	01/14/15	WJ	WJ
18	01/14/15	WJ	WJ
19	01/14/15	WJ	WJ
20	01/14/15	WJ	WJ
21	01/14/15	WJ	WJ
22	01/14/15	WJ	WJ
23	01/14/15	WJ	WJ
24	01/14/15	WJ	WJ
25	01/14/15	WJ	WJ
26	01/14/15	WJ	WJ
27	01/14/15	WJ	WJ
28	01/14/15	WJ	WJ
29	01/14/15	WJ	WJ
30	01/14/15	WJ	WJ
31	01/14/15	WJ	WJ
32	01/14/15	WJ	WJ
33	01/14/15	WJ	WJ
34	01/14/15	WJ	WJ
35	01/14/15	WJ	WJ
36	01/14/15	WJ	WJ
37	01/14/15	WJ	WJ
38	01/14/15	WJ	WJ
39	01/14/15	WJ	WJ
40	01/14/15	WJ	WJ
41	01/14/15	WJ	WJ
42	01/14/15	WJ	WJ
43	01/14/15	WJ	WJ
44	01/14/15	WJ	WJ
45	01/14/15	WJ	WJ
46	01/14/15	WJ	WJ
47	01/14/15	WJ	WJ
48	01/14/15	WJ	WJ
49	01/14/15	WJ	WJ
50	01/14/15	WJ	WJ
51	01/14/15	WJ	WJ
52	01/14/15	WJ	WJ
53	01/14/15	WJ	WJ
54	01/14/15	WJ	WJ
55	01/14/15	WJ	WJ
56	01/14/15	WJ	WJ
57	01/14/15	WJ	WJ
58	01/14/15	WJ	WJ
59	01/14/15	WJ	WJ
60	01/14/15	WJ	WJ
61	01/14/15	WJ	WJ
62	01/14/15	WJ	WJ
63	01/14/15	WJ	WJ
64	01/14/15	WJ	WJ
65	01/14/15	WJ	WJ
66	01/14/15	WJ	WJ
67	01/14/15	WJ	WJ
68	01/14/15	WJ	WJ
69	01/14/15	WJ	WJ
70	01/14/15	WJ	WJ
71	01/14/15	WJ	WJ
72	01/14/15	WJ	WJ
73	01/14/15	WJ	WJ
74	01/14/15	WJ	WJ
75	01/14/15	WJ	WJ
76	01/14/15	WJ	WJ
77	01/14/15	WJ	WJ
78	01/14/15	WJ	WJ
79	01/14/15	WJ	WJ
80	01/14/15	WJ	WJ
81	01/14/15	WJ	WJ
82	01/14/15	WJ	WJ
83	01/14/15	WJ	WJ
84	01/14/15	WJ	WJ
85	01/14/15	WJ	WJ
86	01/14/15	WJ	WJ
87	01/14/15	WJ	WJ
88	01/14/15	WJ	WJ
89	01/14/15	WJ	WJ
90	01/14/15	WJ	WJ
91	01/14/15	WJ	WJ
92	01/14/15	WJ	WJ
93	01/14/15	WJ	WJ
94	01/14/15	WJ	WJ
95	01/14/15	WJ	WJ
96	01/14/15	WJ	WJ
97	01/14/15	WJ	WJ
98	01/14/15	WJ	WJ
99	01/14/15	WJ	WJ
100	01/14/15	WJ	WJ

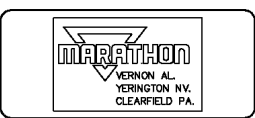

This drawing and all of the information and rights embodied and contained herein, constitutes confidential, proprietary information and trade secrets of Marathon Equipment Company. You are not permitted to use, disclose, distribute, copy, transmit, license, create derivative works from or otherwise reproduce this drawing in whole or in part except as authorized, in writing, by Marathon Equipment Company. You agree to immediately return this drawing and any copies or reproductions thereof upon request by Marathon Equipment Company.

**INTENTIONALLY LEFT BLANK**



# **SECTION 5**

# **REPLACEMENT PARTS**

**CONTACT INFORMATION**



Technical Service and Warranty:

**877-258-1105**

Parts:

**800-528-5308**

For parts visit our eCommerce Marketplace at [www.mecomerchant.com](http://www.mecomerchant.com).

If you do not have a user name and password, contact our Parts Department and they will assist with your registration.

**Normal Business Hours:**

**Monday-Friday            8:00am - 5:00pm**

**(Central Standard Time)**

# Electric Container Dumper Replacement Parts

## ELECTRIC CART DUMPER FRAME, MOTOR AND GEAR BOX

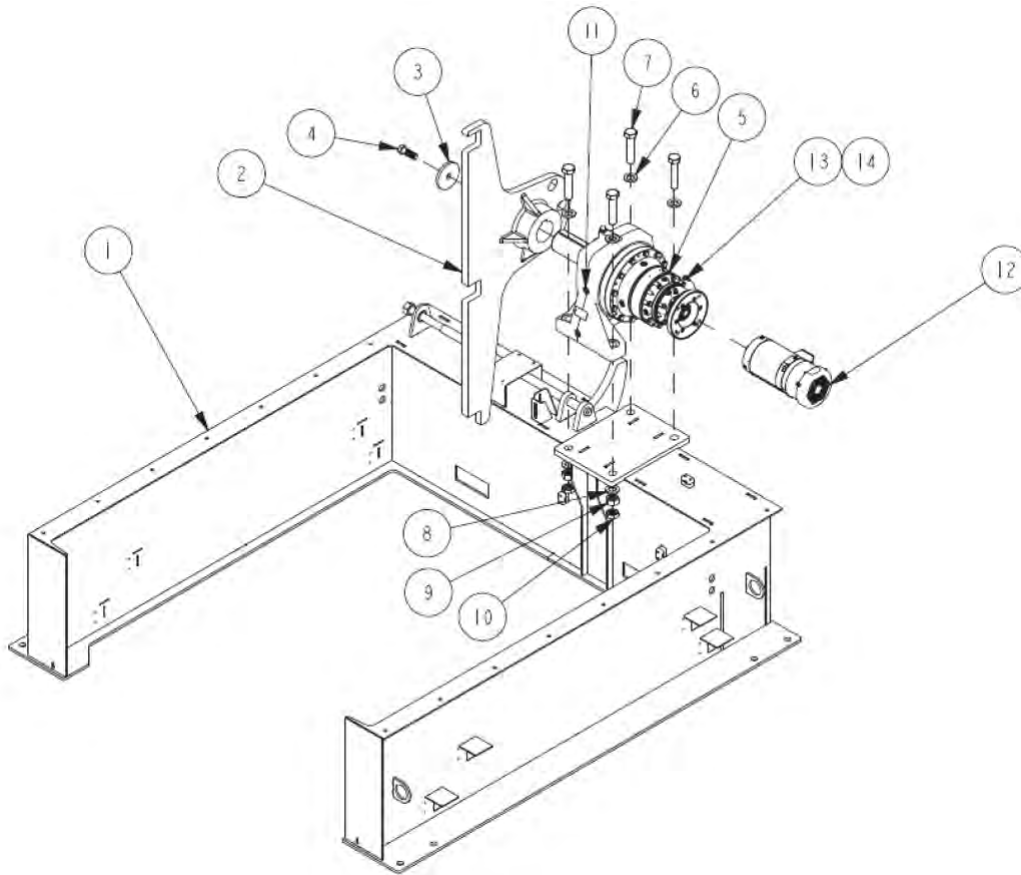

ELECTRIC CART DUMPER FRAME, MOTOR AND GEAR BOX			
REF	QTY	PART NUMBER	DESCRIPTION
1	1	466279	FRAME
2	1	462704	TILTING ASSEMBLY
3	1	36-4300	TILT COVER PLATE
4	1	05-5645	TILT COVER BOLT
5	1	06-4478	GEAR BOX
6	4	05-5952	GEARBOX HARDWARE - TOP WASHER
7	4	05-5565	GEARBOX HARDWARE - BOLT
8	4	05-5456	GEARBOX HARDWARE - BOTTOM WASHER
9	4	05-6024	GEARBOX HARDWARE - PRIMARY NUT
10	4	05-6025	GEARBOX HARDWARE - LOCK NUT
12	1	03-7589	MOTOR 3HP TRI-VOLT
		03-7611	MOTOR 3HP 575 VOLT
13	4	05-0016	MOTOR HARDWARE - WASHER
14	4	05-0096	MOTOR HARDWARE - NUT

# Electric Container Dumper Replacement Parts

## ELECTRIC CART DUMPER TILT TRUCK BOX AND RETAINER

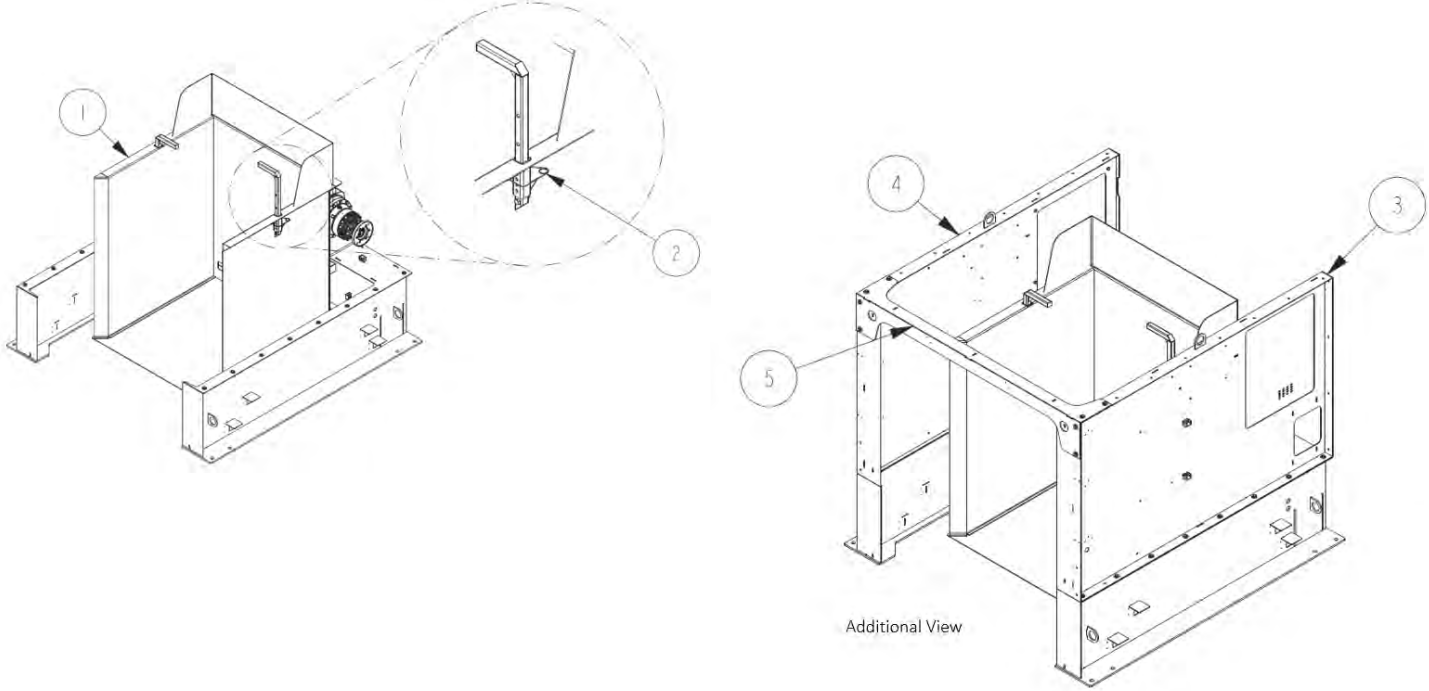

ELECTRIC CART DUMPER TILT TRUCK BOX AND RETAINER			
REF	QTY	PART NUMBER	DESCRIPTION
1	1	466276	TILT TRUCK BOX WITH RETAINER
2	2	05-0513	SNAP PIN
3	1	466272	CAGE - LH
4	1	466273	CAGE - RH
5	1	464700	CAGE CROSS BAR

# Electric Container Dumper

## Replacement Parts

### ELECTRIC CART DUMPER ELECTRICAL

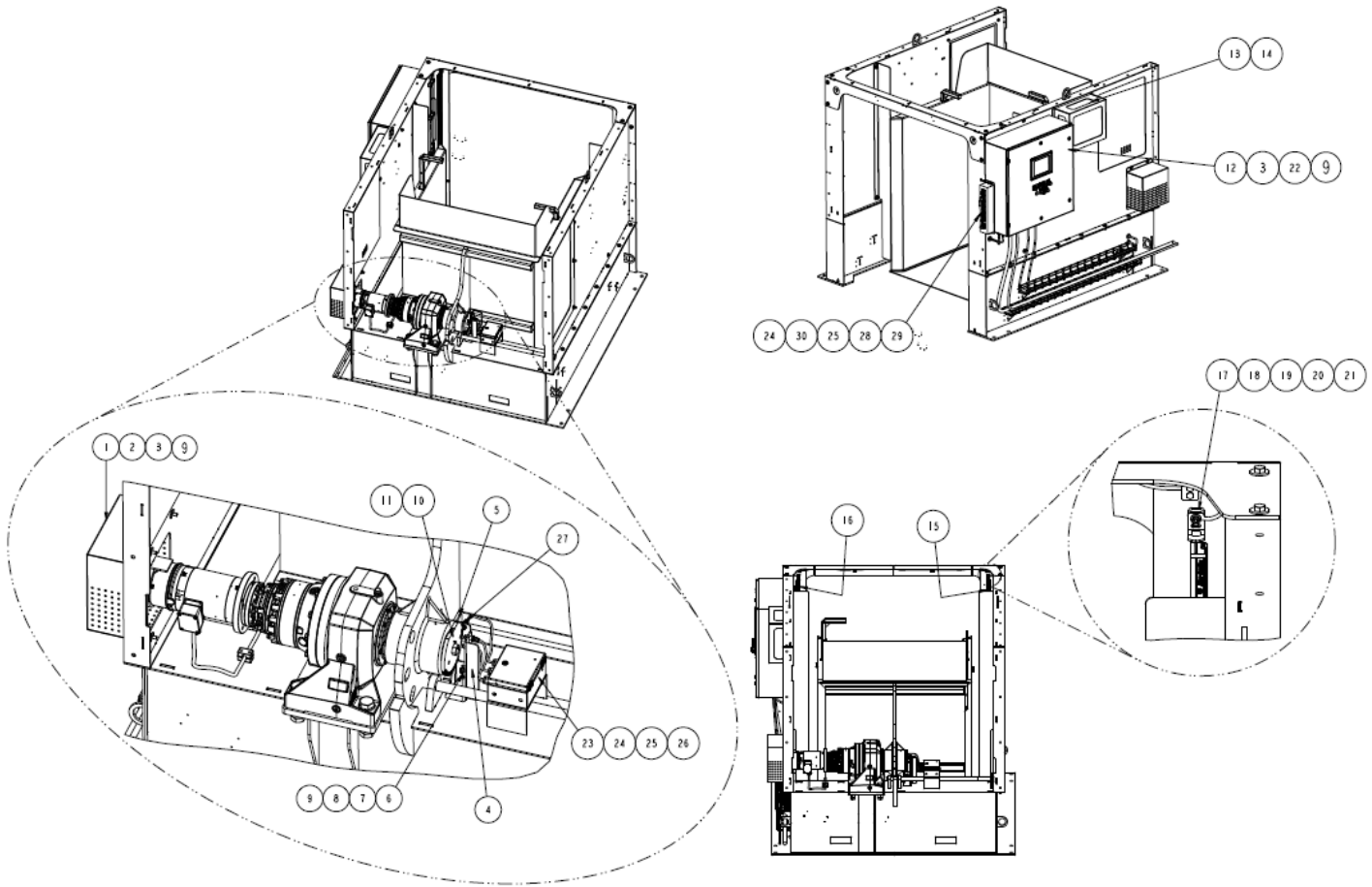

ELECTRIC CART DUMPER ELECTRICAL			
REF	QTY	PART NUMBER	DESCRIPTION
1	1	462992	MOTOR COVER CAGE
2	4	05-0159	MOTOR CAGE HARDWARE - WASHER
3	8	05-0012	MOTOR CAGE , PANEL BOX - BOLT
4	1	37-4975	PROXIMITY SWITCH HARDWARE - BRACKET
5	1	37-4976	PROXIMITY SWITCH HARDWARE - BRACKET
6	4	05-0012	PROXIMITY SWITCH HARDWARE - BOLT
7	4	05-5252	PROXIMITY SWITCH HARDWARE - NUT
8	4	05-0159	PROXIMITY SWITCH HARDWARE - WASHER
9	16	05-0016	MOTOR COVER CAGE, PROXIMITY SWITCH HARDWARE, PANEL BOX - WASHER
10	1	36-6776	COUNTER WHEEL
11	1	05-5909	COUNTER WHEEL HARDWARE - PIN
12	1	466282	PANEL BOX - MAIN
13	1	03-7473	BRAKE RESISTOR
14	1	466271	BRAKE RESISTOR COVER
15	1	03-7501	LIGHT CURTAIN RECIEVER

# Electric Container Dumper

## Replacement Parts

ELECTRIC CART DUMPER ELECTRICAL			
REF	QTY	PART NUMBER	DESCRIPTION
16	1	03-7502	LIGHT CURTAIN TRANSMITTER
17	4	37-0539	LIGHT CURTAIN HARDWARE - SPACER
18	4	05-5916	LIGHT CURTAIN HARDWARE - BOLT
19	8	05-0114	LIGHT CURTAIN HARDWARE - WASHER
20	4	05-5917	LIGHT CURTAIN HARDWARE - NUT
21	4	05-2028	LIGHT CURTAIN HARDWARE - WASHER
22	4	05-0015	PANEL BOX HARDWARE- NUT
23	1	03-5554	PANEL BOX - PROXIMITY SWITCH
24	20	05-0114	PANEL BOX HARDWARE, PUSH BUTTON STN, PROXIMITY SWITCH -WASHER
25	4	05-0025	PANEL BOX HARDWARE - NUT
26	4	05-2461	PANEL BOX HARDWARE - BOLT
27	3	03-4189	PROXIMITY SWITCH
28	1	37-5144	PUSH BUTTON STN HARDWARE -BRACKET
29	1	466281	PUSH BUTTON STN
30	8	05-2591	PUSH BUTTON STN HARDWARE -SCREW

# Electric Container Dumper

## Replacement Parts

### BRAKE MOTOR REPLACEMENT PARTS

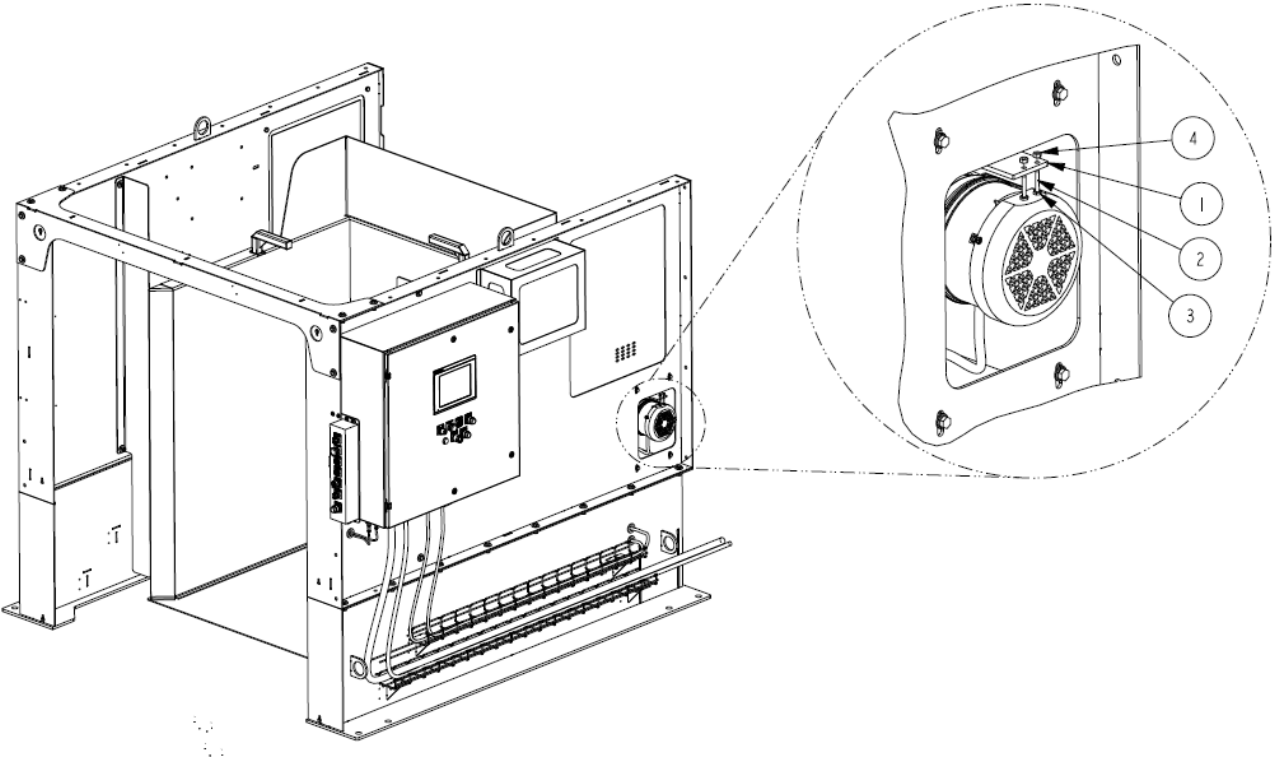

ELECTRIC CART DUMPER BRAKE			
REF	QTY	PART NUMBER	DESCRIPTION
1	1	36-5183	BRAKE MOTOR GUARD
2	2	05-4697	LOCKING PLATE BOLT
3	2	05-0113	LOCKING PLATE NUT
4	2	05-0010	BRAKE LOCKING NUT

# Electric Container Dumper

## Replacement Parts

### DECAL PLACEMENT

Refer to **Decal Images** 78) for illustrations of individual decals.

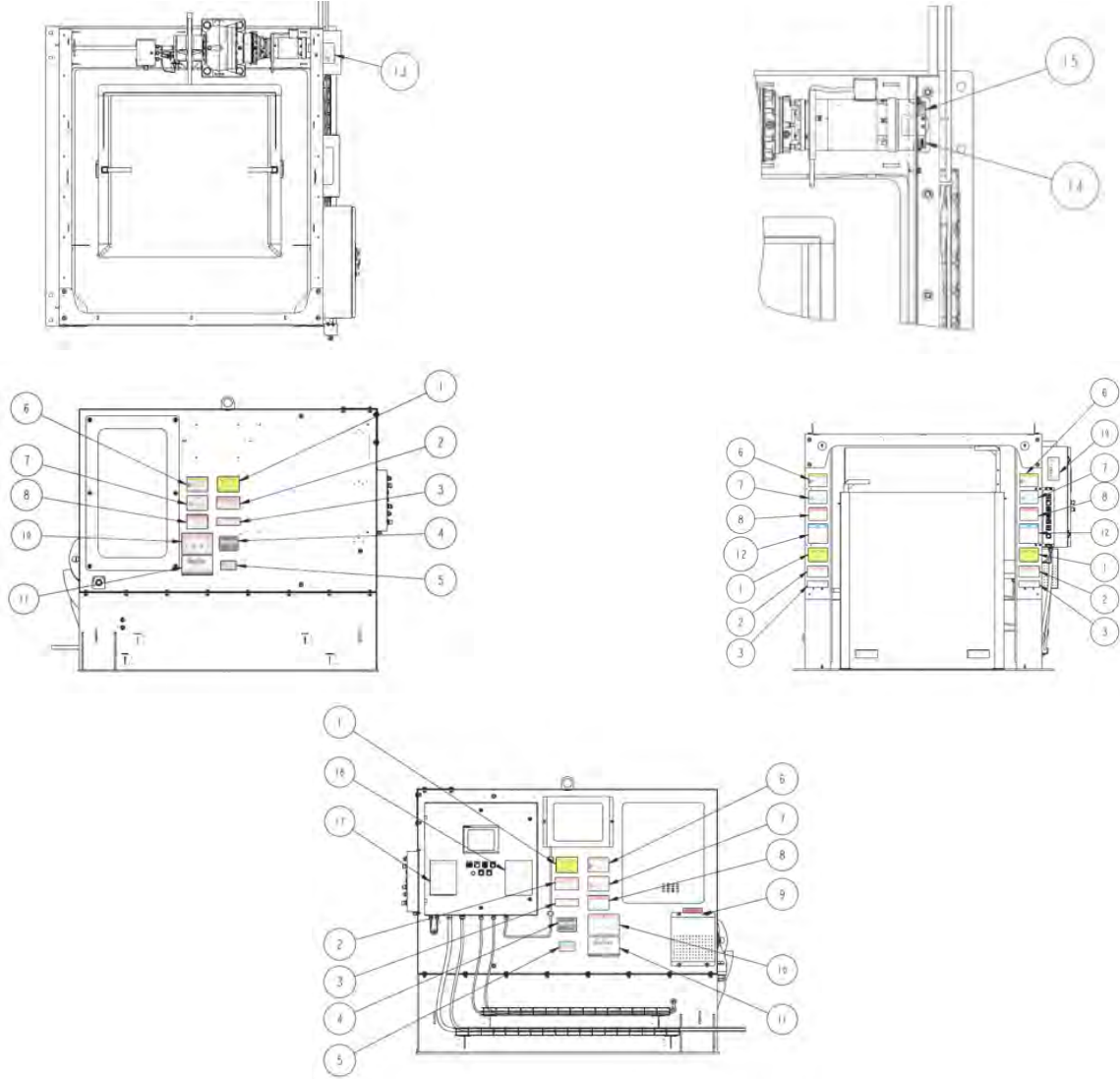



# Electric Container Dumper

## Replacement Parts

### DECAL PLACEMENT (CONTINUED)

ELECTRIC CART DUMPER - DECALS				
REF	QTY	E/S OR E/F	PART NUMBER	DESCRIPTION
1	4	E/S OR E/F	06-4620	DECAL, CAUTION - MAX CAPACITY OF CART DUMPER IS 2000 LBS
2	4	E/S	06-4608	DECAL DANGER FAILURE TO COMPLY
	4	E/F	06-4612	
3	4	E/S	06-0250	DECAL DANGER LOCK OUT POINT
	4	E/F	06-3580	
4	2	E/S OR E/F	06-0002	DECAL DANGER RAM-JET
5	2	E/S OR E/F	06-1839	DECAL AMERICAN FLAG
6	4	E/S	06-3977	DECAL WARNING DO NOT OPERATE
	4	E/F	06-3988	
7	4	E/S	06-0411	DECAL DANGER STAY CLEAR OF DUMPER
	4	E/F	06-0707	
8	4	E/S	06-3978	DECAL DANGER DO NOT OVERRIDE
	4	E/F	06-3989	
9	1	E/S	06-4602	DECAL DANGER FAILURE TO COMPLY
	1	E/F	06-4609	
10	2	E/S	06-0249	DECAL DANGER HAZARDOUS VOLTAGE
	2	E/F	06-0508	
11	2	E/S OR E/F	06-2751	DECAL MARATHON COMP AND RECY
12	2	E/S	06-0121	DECAL NOTICE FEDERAL REGULATIONS
	2	E/F	06-0696	
13	1	E/S	06-0038	DECAL DO NOT REMOVE
	1	E/F	06-0504	
14	1	E/S	06-4603	DECAL BRAKE ENGAGED ARROW
	1	E/F	06-4610	
15	1	E/S	06-4604	DECAL BRAKE DISENGAGED ARROW
	1	E/F	06-4611	
16	1	E/S OR E/F	06-4721	DECAL TROUBLESHOOTING INSTRUCTIONS
17	1	E/S OR E/F	06-4722	DECAL OPERATION INSTRUCTIONS
18	1	E/S OR E/F	06-4723	DECAL STACK LIGHT DESCRIPTION

# Electric Container Dumper Replacement Parts

## DECAL IMAGES

### Warning Decal Requirements

When your dumper leaves the factory, several WARNING DECALS are installed for your protection. These labels are subject to wear and abuse due to the nature of the refuse handling operation. The following decals must be maintained. Additional decals may be purchased through your distributor or from Marathon Equipment Company by calling the service department at 877-258-1105.

06-0002



06-0038



06-0121

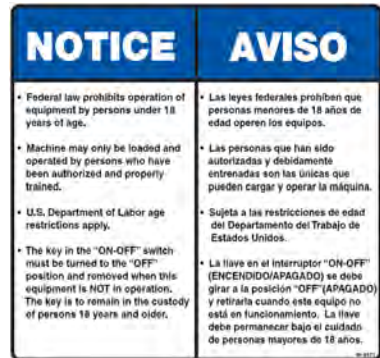

06-0249



06-0250

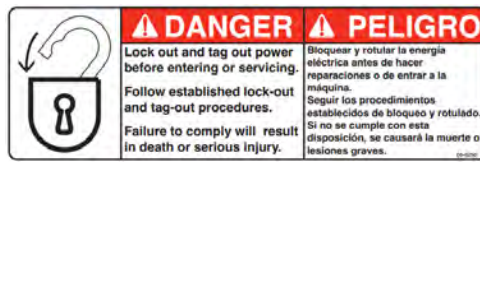

06-0411



06-0504



06-0508



06-0707



# Electric Container Dumper Replacement Parts

## DECAL IMAGES

### Warning Decal Requirements

When your dumper leaves the factory, several WARNING DECALS are installed for your protection. These labels are subject to wear and abuse due to the nature of the refuse handling operation. The following decals must be maintained. Additional decals may be purchased through your distributor or from Marathon Equipment Company by calling the service department at 877-258-1105.

06-0696

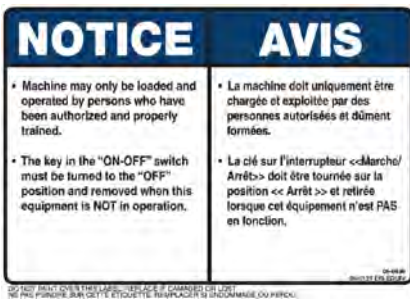

06-1839

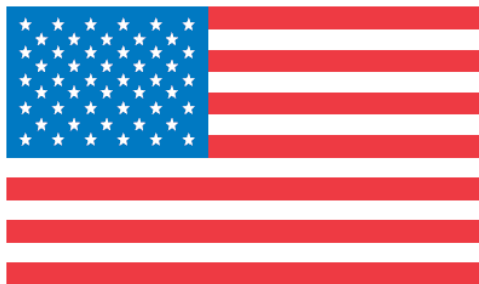

06-2751



06-3580



06-3977



04-4620



06-3988



06-3989

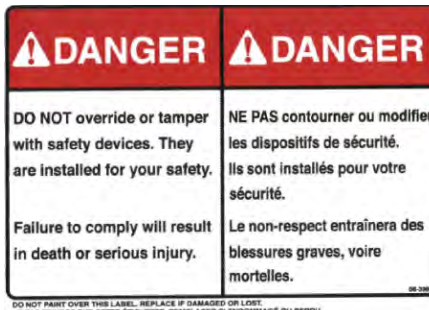

06-4602





# Electric Container Dumper Replacement Parts

## DECAL IMAGES

### Warning Decal Requirements

When your dumper leaves the factory, several WARNING DECALS are installed for your protection. These labels are subject to wear and abuse due to the nature of the refuse handling operation. The following decals must be maintained. Additional decals may be purchased through your distributor or from Marathon Equipment Company by calling the service department at 877-258-1105.

06-4603

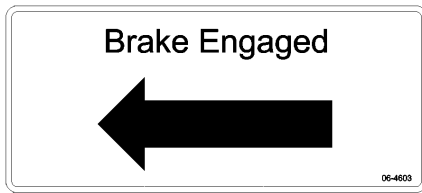

06-4604

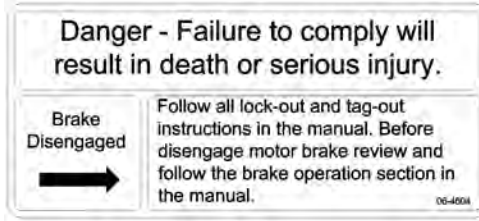

06-4610

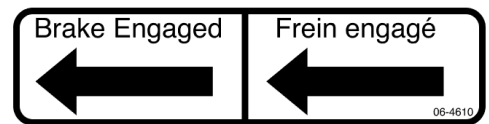

06-4609

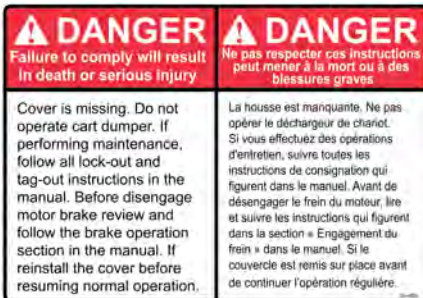

06-4608



06-3978

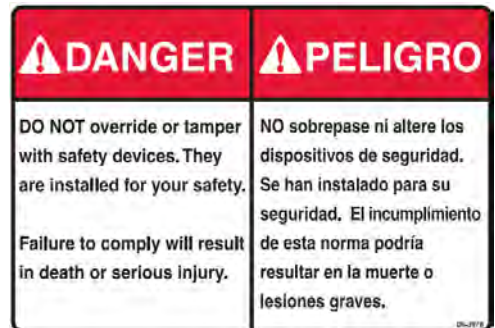

06-4612



06-4611

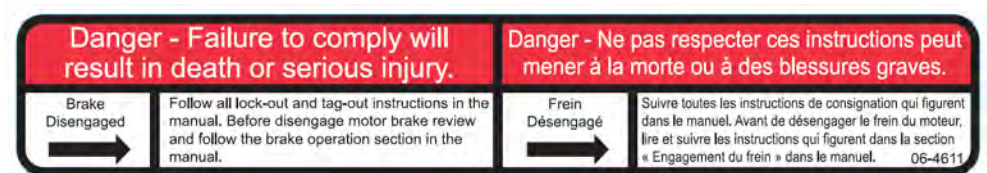

# Electric Container Dumper Replacement Parts

## DECAL IMAGES (CONTINUED)

06-4722



### PRE-OPERATION INSTRUCTIONS

Employers should allow only authorized and thoroughly trained personnel to operate Electric container dumper. Electric container dumper is equipped with a key operated locking system. Keys should be in possession of only authorized personnel. Turn off and remove the key after use.

### OPERATING INSTRUCTIONS FOR DUMPER

#### **Sustained-Manual-Pressure Control Operation Instructions:**

1. Make sure all E-Stop buttons are pulled out. Using the auger compactor controls make sure E-Stop circuit is reset. If the amber button is illuminated, then push the amber button until the light turns off.
2. Push Cart onto dumper. This will break the light curtain causing the amber, Light Curtain Reset, light on the dumper control pendant to illuminate.
3. Reset the light curtain by pushing in on the amber, Light Curtain Reset, illuminated push-button until the light turns off.
4. Place the Dumper Auto/ Manual selector switch in the manual position.
5. Use the Dumper Up/ Down selector switch to raise and lower the dumper as needed.
6. The dumper will stop lifting when the up-proximity switch is activated. The dumper will stop lowering when the down-proximity switch is activated.

#### **Automatic Control Operation Instructions:**

1. Make sure all E-Stop buttons are pulled out. Using auger compactor controls make sure the E-Stop circuit is reset. If the amber button is illuminated, then push the amber button until the light turns off.
2. Place the auger in automatic mode by pressing and holding the Auto Mode button on the touch screen Home screen for 20 seconds. An alarm will sound for 5 seconds and the green strobe light will flash if the auger remains in automatic. The auger will start.
3. Push Cart onto dumper. This will break the light curtain causing the amber, Light Curtain Reset, light on the dumper control pendant to illuminate.
4. Reset the light curtain by pushing in on the amber, Light Curtain Reset, illuminated push-button until the light turns off.
5. Place the Dumper Auto/ Manual selector switch in the Auto position.
6. Choose one or two cycles for the dumper to make by setting the Dumper Cycle selector switch. If two cycles are selected, the dumper will move to fully up position and then move partially down before going back to the fully up position. The dumper will lower when the second cycle is complete. If one cycle is selected, the dumper will move to the fully up position and then back to the down position.
7. Press the Auto Cycle push-button. The dumper will make one or two cycles depending on the setting of the Dumper Cycle selector switch. (Note: If the dumper cycle is interrupted by breaking the light curtain during an auto cycle, the auger and the dumper will be taken out of automatic and stop. The Dumper Auto/ Manual selector switch must be turned to manual and the dumper lowered or raised using the Up/ Down selector switch.)
8. The dumper will stop lifting when the up-proximity switch is activated, after a short pause the dumper will lower. The dumper will stop lowering when the down-proximity switch is activated.
9. When the auto cycle is completed, the cart can be removed from the dumper.

Technical Service and Warranty:

877-258-1105

Parts:

800-528-5308

# Electric Container Dumper Replacement Parts

## DECAL IMAGES (CONTINUED)

06-4721

### Electric Container Dumper Automatic Operation Troubleshooting Guide

**STEP ONE-** Make sure all E-Stop buttons are pulled out. Using the auger compactor controls make sure the E-Stop circuit is reset. If the amber button is illuminated, then push the amber button until the light turns off.

**FIGURE 1** If the amber light does not go off once the button is depressed, check all E-stops to ensure that they are pulled out. There are total three E-stops on the unit located on,  
 1. Main control panel face 2. Remote push button station 3. Right side of the auger body.

If all E-stops have been checked and verified that they are all pulled out, and the amber reset light does not go off after the pushbutton is depressed call Marathon Technical Service.

**STEP TWO-** Place the auger in automatic mode by pressing and holding the Auto Mode button on the touch screen - Home screen for 20 seconds. An alarm will sound for 5 seconds and the green strobe light will flash if the auger remains in automatic. The auger will start.

If the alarm does not begin to sound when the auto button is depressed check the alarm banner on the touchscreen. The following faults could prevent you from starting in automatic.  
 1. ESTOP PRESSED  
 2. LIGHT CURTAIN TRIPPED  
 3. MULTIPLE FAULTS

The alarm banner must read COMPACTOR OK and the dumper be in the full down position to start up in automatic. If the alarm banner reads COMACTOR OK and the unit will not start the automatic sequence, check all the alarm lights on the panel box face and the remote controls pendent.

If the following below occurs:

- Safety relay rest amber push button is illuminated refer to **FIGURE 1** to check all the E-Stop circuits.
- Overload Tripped amber pushbutton is illuminated, depress the button to reset the overload light. If the overload illuminated pushbutton does not reset call Marathon Technical Service.
- Container Gone Red pushbutton is illuminated, confirm that the container has been replaced on the compactor and depress the pushbutton to reset the container gone function.
- Container has been replaced, and the depressing the container gone pushbutton does not reset the illuminated red light. Inspect the container gone sensor for damage. The sensor is located on the compactor hopper body. If no damage is discovered call Marathon Technical Service.

**FIGURE 2** If the Light Curtain Reset amber pushbutton is illuminated, depress the pushbutton to reset the light curtains. If the illuminated pushbutton does not reset, verify that there is nothing blocking the path of the light curtain. If the light curtain path is clear inspect the lights located at the top of each light curtain

Check the status of each light located on the light curtain to verify light curtain function and alignment.

1. STS light should be green, this indicates that the light curtain has power and the system is ok. If the STS light is solid red or blinking green or red call Marathon Technical Service.
2. The next two lights indicate if the curtain is a transmitter or a receiver. If the top one is solid green, then you are looking at the Transmitter. If the bottom one is solid green you are looking at the Receiver. If one of these two lights are blinking call Marathon Technical Service.
3. OUT light will only be illuminated on the receiver and should be solid green. This light will not function on the transmitter. If this light is illuminated red call Marathon Technical Service.
4. The regional light intensity level 1 light indicates the status of the bottom half of the light curtain. If the light is solid green, then that half of the light curtain is OK. If the light is blinking green, then the bottom half of the light curtain is reaching its function zone limit and should be realigned. If this light is off, then something is blocking the function zone, or it is out of alignment beyond its function zone and must be realigned.
5. The regional light intensity level 2 light indicates the status of the top half of the light curtain. If the light is solid green, then that half of the light curtain is OK. If the light is blinking green, then the top half of the light curtain is reaching its function zone limit and should be realigned. If this light is off, then something is blocking the function zone, or it is out of alignment beyond its function zone and must be realigned.
6. RES light indicates the start function. This light should be off to start the cart dumper. If this light is illuminated amber, and all other above lights are in an OK status, then depress the light curtain rest button on the remote controls pendent and the RES light will go off. The light curtain is now reset.

**STEP THREE-** Push Cart onto dumper. This will break the light curtain causing the amber button to illuminate, Light Curtain reset status light on the dumper control pendant to illuminate.

**STEP FOUR-** Reset the light curtain by pushing in on the amber. Light Curtain Reset, illuminated push-button until the light turns off. If the light does not go off refer to **FIGURE 2** to reset the light curtain.

**STEP FIVE-** Place the Dumper Auto/ Manual selector switch in the Auto position.

**STEP SIX-** Choose one or two cycles for the dumper to make by setting the Dumper Cycle selector switch. If two cycles are selected, the dumper will move to fully up position and then move partially down before going back to the fully up position. The dumper will lower when the second cycle is complete. If one cycle is selected, the dumper will move to the fully up position and then back to the down position.

**STEP SEVEN-** Press the Auto Cycle push-button. The dumper will make one or two cycles depending on the setting of the of the Dumper Cycle selector switch. (Note: If the dumper cycle is interrupted by breaking the light curtain during an auto cycle, the auger and the dumper will be taken out of automatic and stop. The Dumper Auto/ Manual selector switch must be turned to manual and the dumper lowered or raised using the Up/ Down selector switch.

**STEP EIGHT-** The dumper will stop lifting when the up-proximity switch is actuated, indicates it is fully up. After a short pause the dumper will lower. The dumper will stop lowering when the down -proximity switch is actuated.

**STEP NINE-** When the auto cycle is completed, the cart can be removed from the dumper.

If the compactor drops out of auto mode during a cycle check the Compactor Status indicator on the touchscreen. The following faults could be present.

SI.No	Faults	Actions if fault is indicated:
1.	ESTOP PRESSED	Refer to <b>FIGURE 1</b> to reset E-stop circuit.
2.	BOTH MOTORS DID NOT START	Call Marathon Technical Service
3.	REVERSING STARTER DID NOT CHANGE STATE	Call Marathon Technical Service
4.	PHOTOCELL BLOCKED AUTO SHUTDOWN	Check the lower photocell located in the hopper to see if it is blocked. If the photocell is not blocked and the fault will not clear, call Marathon Technical Service
5.	MAX AMP COUNT REACHED	Call Marathon Technical Service
6.	START PUSH BUTTON FAULT	Call Marathon Technical Service
7.	LIGHT CURTAIN TRIPPED	Refer to <b>FIGURE 2</b> to reset light curtains.
8.	MULTIPLE FAULTS	You have multiple system faults. Begin at STEP ONE of this guide to eliminate each fault until Compactor OK status is achieved.
9.	DUMPER MOVED AFTER SHUTDOWN CHECK MOTOR BRAKE	Refer manual for motor brake inspection instructions.

**Technical Service**

**877-258-1105**

Note: **FIGURE 1** is in page 34 and **FIGURE 2** is in page 39 of Electrical cart dumper manual.

# Electric Container Dumper Replacement Parts

## DECAL IMAGES (CONTINUED)

06-4723

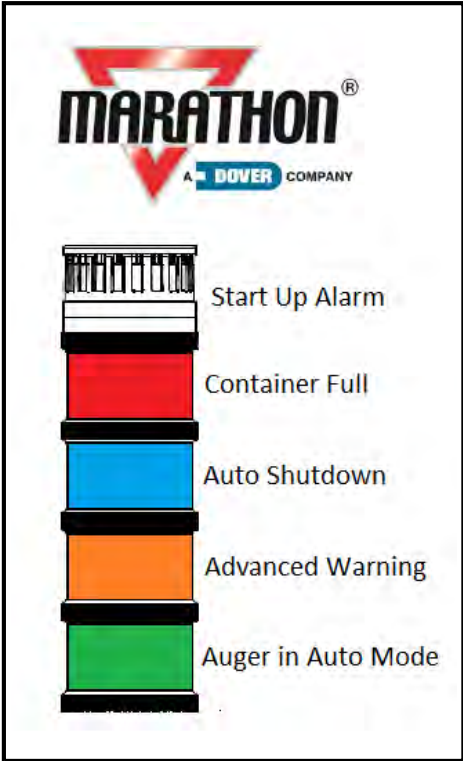

**INTENTIONALLY LEFT BLANK**



# Electric Container Dumper

## INDEX

- A**
- anchoring 19
  - automatic control operation instructions (if equipped) 32
  - automatic operation troubleshooting guide 34
- C**
- circuit breakers 60
  - components 8
  - concrete pad requirements 19
  - contact information 18, 24, 50, 70
  - control panel for auto-cycle function 27
  - control panel for manual controls 26
- D**
- decal care 13
  - decal images 78, 81, 82, 83
  - decal placement 76
- E**
- e-2014 plc circuits 66
  - electrical and hydraulic installation
    - electrical connections 20
    - grounding instructions 20
    - hydraulic connections 20
    - start-up instructions 20
  - electrical charts 60
  - electrical schematic 61
  - electrical schematic for e-2014 motor and e-stop circuits 66
  - electrical symbols 15
- F**
- fuses 60
- G**
- grease lubrication recommendation 12
  - guarding for automatically operated dumpers 19
  - guards and access covers 12
- I**
- introduction 4
- L**
- Lock-Out/Tag-Out 6, 51
- M**
- maintenance stop 58
  - motor starters and heater elements 60
- N**
- nomenclature 8
- O**
- operating instructions 32
- P**
- periodic maintenance 53
  - preface 5
  - pre-operation instructions 25
  - principles of operation
    - dumper with automatic control operating characteristics 59
    - dumper with sustained-manual-pressure controls operating characteristics 59
- R**
- recommended oils 12
  - replacement parts 69
    - brake motor 71
    - electrical 71
    - frame, motor and gear box 71
    - tilt truck box and retainer 71
- S**
- safety symbols and definitions 5
  - service/parts assistance 12
  - sustained-manual-pressure control operation instructions 32
- W**
- warning decals on the unit 13
  - wire sizes 60



[www.marathonequipment.com](http://www.marathonequipment.com)

Customer Care:  
800-633-8974

Parts Central:  
800-528-5308  
[www.mecomerchant.com](http://www.mecomerchant.com)

Technical Service and Warranty:  
877-258-1105

Customer Support:

Marathon Equipment Company  
P.O. Box 1798  
Vernon, AL 35592-1798