



RamJet® Stationary Auger Compactor

AST-220, AST-320, AST-440

OPERATION, SERVICE, AND INSTALLATION
ISSUED MARCH 2020

CUSTOMER NAME: _____

SERIAL NUMBER: _____

COMPACTION & RECYCLING SOLUTIONS

0016-2-RJAST-0320



© 2020 Marathon Equipment Company



Environmental Solutions Group
2030 Hamilton Place Blvd., Suite 200
Chattanooga, TN 37421
Marathon Customer Care: 1.800.633.8974



WARNING

IF INCORRECTLY USED, THIS EQUIPMENT CAN CAUSE SEVERE INJURY. THOSE WHO USE AND MAINTAIN THE EQUIPMENT SHOULD BE TRAINED IN ITS PROPER USE, WARNED OF ITS DANGERS, AND SHOULD READ AND FULLY UNDERSTAND THIS ENTIRE MANUAL BEFORE ATTEMPTING TO SET UP, OPERATE, ADJUST OR SERVICE THE EQUIPMENT. KEEP THIS MANUAL FOR FUTURE REFERENCE

IMPORTANT SAFETY NOTICE

Proper service and repair are important to the safe, reliable operation of the Marathon Equipment Company products. Service procedures recommended by Marathon Equipment Company are described in this Operation, Service, and Installation Manual and are effective for performing service operations. Some of these service operations may require the use of tools or blocking devices specially designed for the purpose. Special tools should be used when and as recommended. It is important to note that some warnings against the use of specific methods that can damage the product or render it unsafe are stated in the service manual. It is also important to understand these warnings are not exhaustive. Marathon Equipment Company could not possibly know, evaluate and advise the service trade of all conceivable ways in which service might be done or of the possible hazardous consequences of each method. Consequently, Marathon Equipment Company has not undertaken any such broad evaluations. Accordingly, anyone who uses service procedures or tools which are not recommended by Marathon Equipment Company must first satisfy himself thoroughly that neither his safety nor the product safety will be jeopardized by the method he selects.

RamJet® Stationary Auger Compactor

TABLE OF CONTENTS

General Information

Introduction	4
Preface	5
Hazard Symbols and Definitions	5
Lock-Out/Tag-Out Instructions	6
Service/Parts Assistance	8
Guards and Access Covers	8
Grease Lubrication Recommendation	8
Recommended Oils for Gearbox	8
Warning Decals on the Unit	9
Decal Care	9
Electrical Symbols	11

Installation

Contact Information	14
Concrete Pad Requirements	15
Steel Installation Procedures	16
Electrical Installation	17

Operation

Contact Information	20
Compactor Pre-Operation Instructions	21
Standard Control Panel	22
Operating Instructions - Photoelectric Cycle Controls	23
Optional Controls	24

Service

Contact Information	26
Periodic Maintenance	27
Maintenance Schedule Form	28
Bearing Lubrication	30
Chain Tension and Adjustment	33
Hard Surface Weld	37
Principles of Operation	39
Fuses, Circuit Breaker, & Wire Size Charts	39
PLC Maintenance - Layout & Description	42
PLC Maintenance - Forward/Reverse Timer Adjustment	43
Electric Schematic	44
Troubleshooting Chart	45

Replacement Parts

Contact Information	48
Typical Panel Box Configuration	49
Decal Parts List	50
Decal Placement	51
Decal Placement for Optional Loading Configurations	52
Decal Images	54
Spare Parts Lists	56

Index	61
--------------------	----

RamJet[®] Stationary Auger Compactor

INTENTIONALLY LEFT BLANK

RamJet® Stationary Auger Compactor
AST-220, AST-320, AST 440

OPERATION, SERVICE, AND INSTALLATION

ISSUED MARCH 2020

0016-2-RJAST-0320

INTENTIONALLY LEFT BLANK

SECTION 1

GENERAL INFORMATION

RamJet® Stationary Auger Compactor

General Information

INTRODUCTION

Thank you for purchasing a Marathon® RamJet® Stationary Auger Compactor!

This product is designed to give you reliable service and superior performance for years to come. The purpose of this manual is to provide the owner and/or operators with the necessary information to properly install, operate, and maintain the machine. Also included are sections regarding troubleshooting and service procedures. The manual is not intended as a primary training source, but as a reference guide for authorized, trained personnel. Each person involved in the operation, maintenance, and installation of the machine should read and thoroughly understand the instructions in this manual and follow ALL warnings.

Employers involved in the operation, maintenance, and installation of the machine should also read and understand the most current version of the following applicable standards:

A copy of this standard may be obtained from:

**ENVIRONMENTAL INDUSTRIES ASSOCIATION
4301 CONNECTICUT AVENUE, NW SUITE 300
WASHINGTON, D.C. 20008**

OSHA Standards - 29 CFR

Refer to:

- Part 1910.147: "The Control of Hazardous Energy (Lock-Out/Tag-Out)"
- Part 1910.212: "Machinery and Machine Guarding: General Requirements for all Machines"
- All other applicable OSHA Standards

ANY SERVICE OR REPAIRS THAT GO BEYOND THE SCOPE OF THIS MANUAL SHOULD BE PERFORMED BY FACTORY AUTHORIZED PERSONNEL ONLY!

If you should need further assistance, please contact your distributor. You will need to provide the equipment serial number, installation date, and electrical schematic number to your distributor.

If you have any safety concerns with the equipment or need further information, please contact us at:

**Marathon Equipment Company
P.O. Box 1798
Vernon, AL 35592-1798
Attn: Field Service Department
877-258-1105**

PREFACE

The following sections are a guide for maintenance and service of the Marathon Equipment Company unit. The sections cover preventive maintenance, adjustment, and troubleshooting hints. Before performing maintenance, check the work area carefully to find all the hazards present and make sure all necessary safeguards or safety devices are used to protect all persons and equipment involved. In order to diagnose a problem quickly and effectively, a service person must be thoroughly familiar with the machine. This Operation, Service, and Installation Manual explains the system and its major components. Diagrams and schematics of the electrical systems are in the Service Section.



IMPORTANT!

- Before starting any maintenance, study this section of the manual.
- Read all hazard warnings and decals on the unit.
- Clear the area of other persons before performing any maintenance.
- Know and understand safe use of all controls.
- It is your responsibility to understand and follow manufacturer's instructions on equipment and care.

HAZARD SYMBOLS AND DEFINITIONS

Listed below are the definitions for the various levels of hazards. It is important that the operators of this equipment and people who service units read and understand all warnings as they relate to this equipment operation.

- **DANGER** – indicates an imminently hazardous situation, which **WILL** result in **DEATH** or **SERIOUS INJURY** if you don't follow proper instructions.
- **WARNING** – indicates an imminently hazardous situation, which **COULD** result in **DEATH OR SERIOUS INJURY** if you don't follow proper instructions.
- **CAUTION** – indicates an imminently hazardous situation, which will result in **MINOR** to **MODERATE INJURY** if you don't follow proper instructions.
- **NOTICE** – means unit or other property may be damaged if these instructions are not followed.

You must read and obey all warnings in any manual produced by Marathon Equipment Company to support your unit.

LOCK-OUT & TAG-OUT INSTRUCTIONS

DANGER



Before entering any part of the compactor, be sure that all sources of energy have been shut off, all potential hazards have been eliminated, and the compactor is locked-out and tagged-out in accordance with OSHA and ANSI requirements.

The specific Lock-Out and Tag-Out instructions may vary from company to company (i.e. multiple locks may be required, or other machinery may need to be locked-out and tagged-out). The following instructions are provided as minimum guidelines.

INSTRUCTIONS

1. Notify all affected employees that servicing or maintenance is required on the compactor and that the compactor must be shut down and locked out to perform the servicing or maintenance.
2. Perform a hazard assessment;
 - a. The authorized employee shall refer to the company procedure to identify the type and magnitude of the energy that the compactor utilizes, shall understand the hazards of the energy, and shall know the methods to control the energy.
3. Wear proper personal protective equipment.
4. If compactor is operating, it must be shut down by the normal stopping procedure. If the ram is pressing against a load, move the ram rearward before shutting the auger down.
5. De-activate the energy isolating device(s) so that auger is isolated from the energy source(s).
 - a. Shut down all power sources.
 - b. Move the main disconnect lever to the OFF position.
6. Lockout the energy isolating device(s) with assigned individual lock(s).
 - a. Padlock the disconnect lever with a keyed padlock and take the key with you.
 - b. Along with the padlock, place an appropriate, highly visible, warning tag on the disconnect lever. The tag should provide a warning such as:
 - “Danger: Do not operate equipment. Person working on equipment.” or
 - “Warning: Do not energize without the permission of _____.”
 - c. Place operating components in such a position so as not to be subject to possible free fall and/or install additional blocking devices to prevent this potential for any raised or elevated component.
7. After locking and tagging the compactor, ensure that the auger is disconnected from the energy source by first checking that no personnel are exposed, then verify the isolation of the equipment by operating the push button or other normal operating control(s) or by testing to make certain the equipment will not operate. Try to start and operate the compactor (as outlined in the Operating Instructions) to make sure the Lock-Out and Tag-Out is effective. If the Lock-Out and Tag-Out is effective, remove the key from the key switch and take it with you.
8. Before entering compactor perform hazard assessment for confined space requirements (hazardous fumes, dust, toxic material, or other hazards) per the OSHA confined space standard.
9. The compactor is now locked out.

LOCK-OUT & TAG-OUT INSTRUCTIONS (CONTINUED)

RESTORING SERVICE

When the servicing or maintenance is completed and the auger is ready to return to normal operating condition, the following steps shall be taken:

1. Check the compactor and the immediate area around the compactor to ensure that nonessential items have been removed and that the compactor components, guards and covers are operationally intact.
2. Check the work area to ensure that all employees have been safely positioned or removed from any hazardous area.
3. Verify that the controls are in neutral.
4. Remove the lockout devices and re-energize the compactor.

NOTICE

The removal of some forms of blocking may require re-energizing of the compactor before safe removal.

5. Notify affected employees that the servicing or maintenance is completed and the compactor is ready for use.
6. Reassess area to determine all hazards are protected.

RamJet[®] Stationary Auger Compactor

General Information

SERVICE/PARTS ASSISTANCE

Assistance in troubleshooting, repair and service is available by contacting the authorized Marathon Equipment Company Dealer in your area. Parts are available at your Marathon Equipment Company Dealer or through Marathon Equipment Company. Marathon Equipment Company personnel are trained to give prompt, professional assistance.

ALWAYS give the machine serial number in all correspondence relating to the equipment.

GUARDS AND ACCESS COVERS

Before operating or performing maintenance, check the work area carefully to find all the hazards present and make sure all guards and safety devices are in place to protect all persons and equipment involved.

WARNING

DO NOT operate without all guards and access covers in place.

GREASE LUBRICANT RECOMMENDATION

Use a grease gun. Before engaging grease gun, clean the fitting. Always pump enough grease to purge the joint of contaminated grease and wipe off the excess grease. Lubricate a unit as recommended on the lubrication decal on the unit and in the Operation, Service, and Installation Manual. Use NLGI 2 grease. The unit is shipped with Nevastane XS 80 grease.

RECOMMENDED OILS FOR GEARBOX

The following oil by brand name is approved for use in the gearbox on this equipment.

- Shell Omala S4 GX150 or Equivalent.

WARNING DECALS ON THE UNIT

WARNING

DO NOT operate without all guards and access covers in place.

Make sure you can read all warning and instruction decals. Clean decals if you cannot read the words. See below for directions on cleaning decals. Replace any decal that is damaged, missing, or is not readable. When you replace a part that has a decal, make sure a new decal is installed on the new part. See the Operation, Service, and Installation Manual for replacement decals. Order replacement decals from Marathon Equipment Company or an authorized dealer.

DECAL CARE

It is important that the decals are properly cleaned to make sure that they are readable and do not come off the unit. Use the following steps to clean the decals.

A. General Instructions

Following these instructions helps the decals adhere longer.

- Wash the decals with a blend of mild car wash detergent and clean water
- Rinse with clean water
- Let the unit air-dry or dry with a micro-fiber cloth
- Do not allow fuels to stay in contact with the decal for an extended period of time. Remove the fuel contamination as quickly as possible
- Do not use carnauba-based wax over the decals
- Do not use a mechanical brush while washing the decals.

B. Pressure Washer Precautions

Pressure washing can cause damage to decals. It can cause the edges of the decals to lift and peel the decal away from the unit. Over time, the decal can fade, crack or chip away.

Use pressure washing only when other cleaning methods are not effective. If you use a pressure washer, use the following precautions.

- Spray nozzle opening: 40° wide pattern
- Spray angle: 65° from vehicle's body
- Distance of nozzle to decal: 15" minimum
- Water pressure: less than or equal to 800 psi
- Length of time: not more than 30 sec.
- Do not use sharp angles to clean the decals – this can lift the decals from the unit.
- NEVER use a "turbo pressure nozzle".

C. Remove Difficult Debris

When normal cleaning procedures do not remove difficult debris from the decals, try the following:

- Spot clean the decal with Isopropyl Alcohol and a micro-fiber cloth (rag)
- If these methods do not work on a problem area, call a Marathon Equipment Company Dealer or Marathon Equipment Company Customer Support.

RamJet® Stationary Auger Compactor

General Information

DECAL CARE - CONTINUED

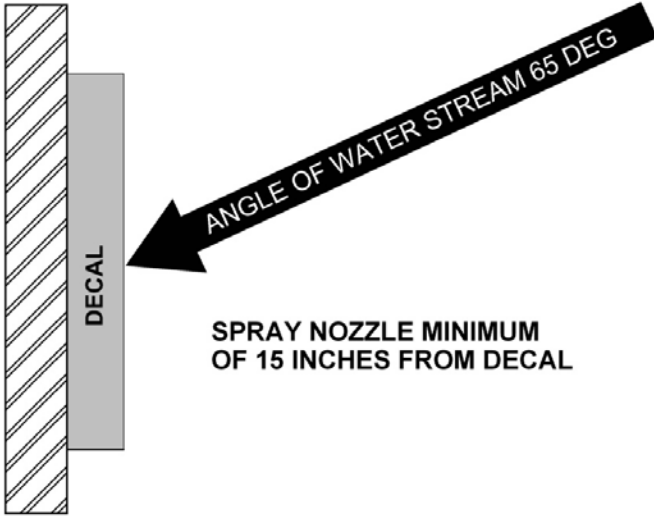



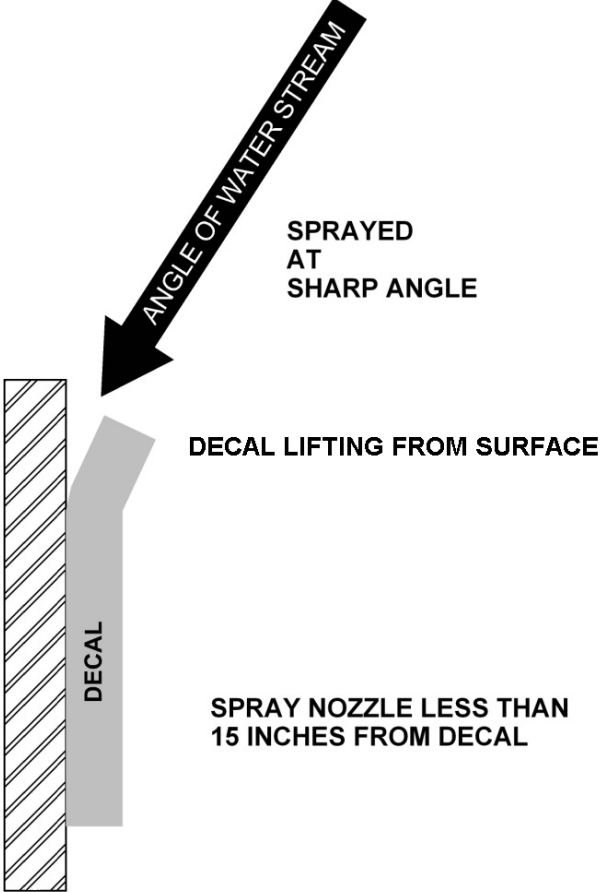









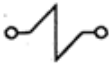

RECOMMENDED TECHNIQUE

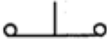

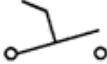
INCORRECT TECHNIQUE

ELECTRICAL SYMBOLS

SYMBOL DEFINITIONS

	BATTERY
	FUSE
	SOLENOID
	CONTACT RELAY
	NORMALLY OPEN CONTACT OF CR1
	NORMALLY CLOSED CONTACT OF CR1
	INDICATOR LIGHT (GREEN)
	PUSH BUTTON SWITCH NORMALLY CLOSED
	PUSH BUTTON SWITCH NORMALLY OPEN
	TOGGLE SWITCH
	DIODE
	PRESSURE SWITCH
	LIMIT SWITCH NORMALLY OPEN
	LIMIT SWITCH NORMALLY CLOSED
	CAPACITOR

INTENTIONALLY LEFT BLANK

SECTION 2

INSTALLATION

CONTACT INFORMATION



Technical Service and Warranty:

877-258-1105

Parts:

800-528-5308

For parts visit our e-commerce market place at www.mecomerchant.com.

If you do not have a user name and password, contact our Parts Department and they will assist with your registration.

Normal Business Hours:

Monday-Friday 8:00am - 5:00pm

(Central Standard Time)

CONCRETE PAD REQUIREMENTS

These installation instructions are not intended as a substitute for training and experience in proper use and safety procedures in operating this equipment.

Marathon Equipment Co. does not assume responsibility for the installation procedures of this equipment. Conformance to applicable local, state, and federal laws concerning installation rests with the customer.

CAUTION

Review this manual before making the installation. Study the job site and installation requirements carefully to be certain all necessary safeguards or safety devices are provided to protect all personnel and equipment during the installation and as a completed system. Special attention is directed to the most current ANSI Z245.2 standard.

Concrete Pad

1. Preferred dimensions of the concrete pad are 10'0" wide and a length of 5'0" greater than the length of the compactor/container. It should be level and of minimum 3000 PSI concrete steel reinforced, 6" thick. It is preferred that the concrete pad be flush with the surrounding ground level.
2. To provide accessibility, concrete pad should be positioned to allow 28" of clearance from outer most protrusion of the lock system of the compactor/container to a wall, building, structure, or container to allow adequate ingress/egress to equipment. Allow a minimum of 45' of clear space from end of pad for container handling vehicle.

NOTICE

The clearances given are minimums. Your installation may require greater clearances depending on the site and the hauling equipment that will be used.

Anchoring

The compactor should be anchored to concrete pad using (8) minimum 3/4" x 6" long anchor bolts. These bolts can be secured to concrete pad using "Porok" or special concrete anchors. It is best if these holes are drilled in the concrete after pre-locating the compactor in its desired location. Holes in the leg plates are 1-5/16" dia. to permit the use of a 1-1/8" dia. concrete bit. The 1-1/8" dia. holes in the concrete should be approximately 5" deep. When the compactor has been permanently located, shimmed to compensate for unevenness, and anchor bolts set, tighten all nuts securely.

Note: Ensure anchor bolts are not allowed to torque or twist the compactor body when tightened.

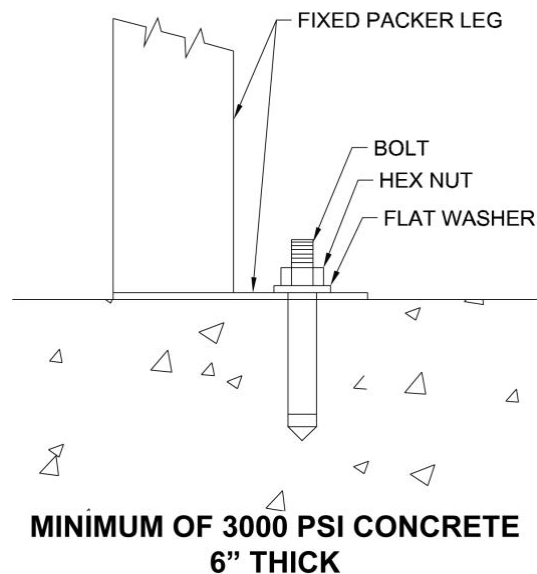

STEEL INSTALLATION PROCEDURES

Dock Installation

If the appropriate accessories are ordered from Marathon Equipment Co., the compactor will be furnished with either a four-sided hopper or a three-sided hopper with a hinged gate. THESE ACCESSORIES SHOULD NOT BE ALTERED AS THEY ARE MANUFACTURED IN ACCORDANCE WITH THOSE STANDARDS WHICH PREVAIL AT THE TIME OF MANUFACTURE.

If the compactor cannot be directly abutted to the dock or if there is any difference in height between the dock and the compactor/container, an appropriately sturdy transition section should be provided by the customer and securely affixed to the dock. Along with the transition section, a compactor/container guidance/stop mechanism should be installed to assure that the unit does not bottom out against the transition section or dock during dock placement (See ANSI Z245.2 Safety Standards). Optional container guides with stops are available from Marathon and are recommended for proper dock placement of the compactor/container.

Chute-Fed Installation

Compactors installed in this arrangement are normally fed "through-the-wall". The lower edge of the access hole in the wall should be a MINIMUM of 42" (and, if possible, not more than 58") from the inside floor level. Also, due to compactor height variations, the bottom of the access hole should be at least 2" above the compactor height. A security door (in accordance with local code) should be installed in the wall opening. In the absence of a local code, this door should be constructed of 3/16" thick steel or of steel hollow core design and be lockable from the inside of the building.

Decals

Be certain that the appropriate decals are in their proper locations at all times on the machine. For decals locations, see **Decals** and **Decal Placement for Standard Units** in the "Replacement Parts" section of this manual.

Note: Installation is not complete until all decals are in place.

Container Guides

If container guides (optional) are used with the compactor and container, each guide should be anchored to the concrete pad with 3/4" x 6" (minimum) anchor bolts. These bolts should be concrete anchors or expansion type anchor bolts. To allow for construction variations, it is best if these holes are drilled in the concrete after pre-locating the container guides in their desired location. When the guides have been placed in position, and the anchor bolts have been set, tighten all nuts securely.

ELECTRICAL INSTALLATION (CONTINUED)

Push-button Control Panel

If a remote push-button station is furnished, it will be factory wired using Sealtite. If it is necessary to disconnect it from the wires (to install the push-button station inside a building), exercise care that these wires are reconnected as originally furnished. (Check local codes to be certain that Sealtite is acceptable.)

CAUTION

Controls must be located so that the Emergency Stop Button is readily accessible to the operator and within three (3) feet of the charging chamber access. If installation requires this pushbutton control station to be located in a more remote area, a second Emergency Stop Button should be added and installed in the manner described above.

Electrical Connections

1. Run power lines between fused disconnect switch (customer furnished) and compactor's electrical panel box, in accordance with local electrical codes, using knock-outs in bottom of panel box. See **Fuse & Circuit Breaker Charts** for Motors and **Wire Size Chart**, in the Service section, to determine the proper service disconnect amperage rating and the proper wire size.

Note: High legs should be installed to L3 on motor starter.

2. Check voltage at fused disconnect switch to be certain it is the same as is shown on compactor or remote power pack.

Start-Up Instructions

CAUTION

Make sure persons and material are clear of charge box area.

Put fused disconnect switch in "ON" position when ready to start machine. Depress the start button and check the motor fan for proper rotation (should be clockwise). Reversing any two incoming power lines should change the motor rotation. Push the start button for the auger to go counter clockwise. Follow all **Lock-Out & Tag-Out Instructions** in the "Service" section.

Make sure that the operators are trained in the proper use of this equipment.

SECTION 3

OPERATION

CONTACT INFORMATION



Technical Service and Warranty:

877-258-1105

Parts:

800-528-5308

For parts visit our e-commerce market place at www.mecomerchant.com.

If you do not have a user name and password, contact our Parts Department and they will assist with your registration.

Normal Business Hours:

Monday-Friday 8:00am - 5:00pm

(Central Standard Time)

PRE-OPERATION INSTRUCTIONS

Employers should allow only authorized and thoroughly trained personnel to operate this compactor.

This compactor is equipped with a key operated locking system. Keys should be in possession of only authorized personnel. Turn off and remove the key after use.

DANGER

ONLY TRAINED AND AUTHORIZED PERSONNEL SHOULD BE ALLOWED INSIDE PANEL BOX. The panel box contains high voltage components. See Lock-Out/Tag-Out Instructions.

WARNING

Do not operate compactor until operating instructions are thoroughly understood. Wear safety glasses and gloves when operating this equipment.

WARNING

Stay clear of all internal compactor parts and all moving external compactor parts when in operation. Failure to do so could result in serious personal injury or death!

WARNING

Never enter any part of compactor unless the disconnect switch has been turned off, padlocked, and all stored energy sources have been removed. See Lock-Out/Tag-Out Instructions.

WARNING

Do not remove access covers except for servicing. Only trained and authorized service personnel should be allowed to service this equipment. All access doors on the compactor body should always be secured in place when the unit is operating. See Lock-Out/Tag-Out Instructions.

WARNING

Before starting compactor, be sure no one is inside. Be certain that everyone is clear of all operation points and pinch point areas before starting.

WARNING

If the compactor is equipped with a security gate or doghouse with security door, be sure that the security gate or door is closed before the compactor is started.

NOTICE

Federal regulation prohibits the use of this equipment by anyone under 18 years of age.

STANDARD CONTROL PANEL



CONTROL DESCRIPTION

1. **KEYED SWITCH** - This switch requires a key for operation. Insert the key and turn counterclockwise to the ON position. The compactor will cycle one time then stop. After use, turn the key clockwise to the OFF position and remove the key.
2. **START PUSH-BUTTON** - This button starts the auger in the Forward/Counterclockwise direction.
3. **EMERGENCY STOP PUSHBUTTON** - When depressed, this pushbutton will stop all powered operation of the compactor.
4. **REVERSE PUSHBUTTON** - This push-button will reverse the auger rotation when depressed. The motor must be running for the REVERSE button to operate. See the **Manual Override Instructions** for details of the operation.

OPERATING INSTRUCTIONS - STANDARD MODELS

WARNING

Use ONLY Marathon reinforced receiver containers with Marathon Stationary Auger Compactors. Use of a non-OEM receiver container with a Marathon Stationary Auger Compactor could result in container damage, property damage, and/or personal injury – up to and including death.

1. First, place the material to be discarded into the compactor.
2. Depress the start button for 1 to 2 seconds and release. The unit will cycle for a predetermined time then stop.
3. Repeat, if necessary, after the compactor has stopped.
4. When you have finished using the compactor, remove the key from the key switch.

IN CASE OF EMERGENCY: Push the large RED button to STOP!

OPERATING INSTRUCTIONS - MODELS WITH PHOTOELECTRIC CYCLE CONTROL

WARNING

Use ONLY Marathon reinforced receiver containers with Marathon Stationary Auger Compactors. Use of a non-OEM receiver container with a Marathon Stationary Auger Compactor could result in container damage, property damage, and/or personal injury – up to and including death.

NOTICE

This compactor features an **ANSI Z245.21-5.12.1** compliant start-up alarm that is both audible and visible during the activation of the **AUTOMATIC** mode.

Operating Instructions (Automatic Mode)

1. First, place the material to be discarded into the compactor.

NOTICE

If you are loading the compactor through a door or gate, close it before starting the compactor. Refer to **Decal Placement for Optional Loading Configurations** to determine how your compactor is configured

2. Insert the first key into the "**MANUAL - OFF - AUTOMATIC**" key switch and turn to the "**AUTOMATIC**" position.
3. Insert the second key into the "**START**" switch and turn to the right.
4. Depress the key in the "**START**" switch and hold it continuously for 20 seconds.

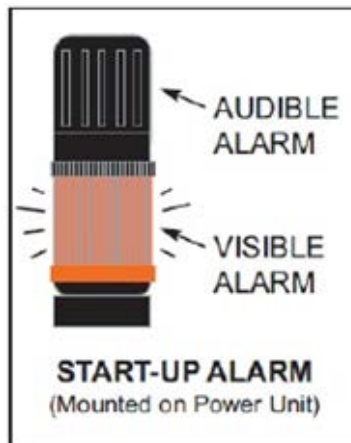

5. Both the audible and visual start-up alarms will energize for 5 seconds.
6. After 5 seconds the audible alarm will stop, but the visual alarm will continue for an additional 15 seconds (for a total of 20 seconds).
7. After 20 seconds, the motor will start and the ram will extend, and then retract (one complete cycle).
8. The light will continue to flash until the unit is manually turned off, automatically shuts down, or is switched to manual mode.

WARNING

In **AUTOMATIC** mode, the power unit will ram automatically anytime photocells detect ANY OBJECT in the charge box.

OPTIONAL CONTROLS

1. **SUSTAINED MANUAL PRESSURE CONTROL BUTTON (Hold-To-Run, Release-To-Stop)** This option requires the compactor operator to remain at the push button station while the compactor is in use. Actuation requires depressing the "Hold-To-Run" and "Start" buttons. After the unit has started, the "Start" button is released. If the "Hold-To-Run" button is released, the unit will stop instantly.
2. **ADVANCE WARNING / CONTAINER FULL LIGHT** - When the light starts flashing (ADVANCE WARNING). When the light stays on continuously (CONTAINER FULL), the container is full and is ready to be emptied before its next use. To deactivate the light, depress the illuminated light (The unit will not run while the light is continuously on).
3. **ACCESS INTERLOCK** - This is optional with units equipped with doors, security doors, or access gates. It prevents the unit from operating while a door or gate is open.
4. **PHOTOELECTRIC CYCLE CONTROL** - (Photocell) - Consists of a LED light source and a reflector. It can be mounted on a hopper or chute. Two holes, located so as to avoid any hazard, are located in opposite walls of the chute. When the light beam is blocked for 5 seconds, the audible alarm will sound for 5 more seconds, then the compactor is activated and will continue to run until the obstruction has been cleared or the watchdog timer times out.
5. **AUTOMATIC SHUTDOWN** - Used with the photoelectric cycle control. If a blockage in the charge chamber causes the compactor to continue cycling, the timer will shut the compactor down after the preset time has passed. To deactivate the timer, the illuminated auto shutdown push-button is pressed after clearing the blockage.
6. **START ON DOOR CLOSURE** - When switch is in auto the PLC counts door closures. The machine will start on predetermined count that is within the PLC.

SECTION 4

SERVICE

CONTACT INFORMATION



Technical Service and Warranty:

877-258-1105

Parts:

800-528-5308

For parts visit our e-commerce market place at www.mecomerchant.com.

If you do not have a user name and password, contact our Parts Department and they will assist with your registration.

Normal Business Hours:

Monday-Friday 8:00am - 5:00pm

(Central Standard Time)

PERIODIC MAINTENANCE

WARNING

Never enter any part of the compactor until the unit has been locked-out and tagged-out.

Monthly

- Check for and correct any unsafe conditions in or around the compactor area.
- Clean debris from under/around the compactor/container.
- Remove rear cover(s) and clean debris from chain/sprocket chamber.
- Grease internal bearings. See bearing lubrication section.
- Check chain for proper tension, see Setting Chain Tension section for details.
- Ensure motor/gearbox/gearbox mounting plate bolts are tight.
- Check oil and oil level in planetary gearbox. Oil should be translucent and proper level is to the top of the sight gauge.
- Check auger screw for material build up (banding, plastic wrap, etc.). Remove if necessary.
- Check auger screw for damage and repair if necessary.
- Inspect hard surface welding on the end of the auger fighting. See hard surface welding section for details.
- Check external cords and flexible conduit for chafing, rubbing, deterioration, or damage. Repair/replace as necessary.

NOTICE

Two grease fitting locations on the AST-440

Quarterly

- Check functional operation of controls and options (stop button, timers, lights, auto-lube, etc.).

Annually

- Lubricate electric motor bearings annually per the manufacturer's instructions.
- Replace gear oil in planetary gearbox.
- Marathon recommends:
 - Valvoline EPG Gear Lube 320 rated 15 to 160 degrees Fahrenheit
 - Valvoline EPG Gear Lube 150 rated -22 to 90 degrees Fahrenheit

RamJet® Stationary Auger Compactor Service

MAINTENANCE SCHEDULE FORM

Make copies of below table to record your maintenance on equipment.

MAINTENANCE SCHEDULE										
MONTHLY										
	CHECK FOR UNSAFE CONDITIONS	CLEAN-UP	GREASE BEARINGS	CHECK/SET CHAIN TENSION	CHECK GEARBOX BOLTS	CHECK OIL LEVEL IN GEARBOX	CHECK AUGER FOR MATERIAL BUILD-UP	INSPECT AUGER	INSPECT HARD SURFACE WELD	CHECK CORDS AND CONDUIT
Jan										
Feb										
Mar										
Apr										
May										
Jun										
Jul										
Aug										
Sept										
Oct										
Nov										
Dec										

RamJet® Stationary Auger Compactor Service

MAINTENANCE SCHEDULE FORM (CONTINUED)

MAINTENANCE SCHEDULE			
	QUARTERLY	ANNUALLY	
	CHECK FUNCTIONAL OPERATION OF CONTROLS	LUBRICATE ELECTRIC MOTOR BEARINGS	REPLACE GEARBOX OIL
Jan			
Feb			
Mar			
Apr			
May			
Jun			
Jul			
Aug			
Sept			
Oct			
Nov			
Dec			

BEARING LUBRICATION

For units equipped with Auto-Lube systems:

1. Fill the grease reservoir per the auto-lube manufacturer's recommendation. The auto-lube system will automatically grease the bearings.
2. Depress the "Auto-Lube" button until grease fresh comes out of the drip hose.
3. Clean the excess grease from the drip pan.

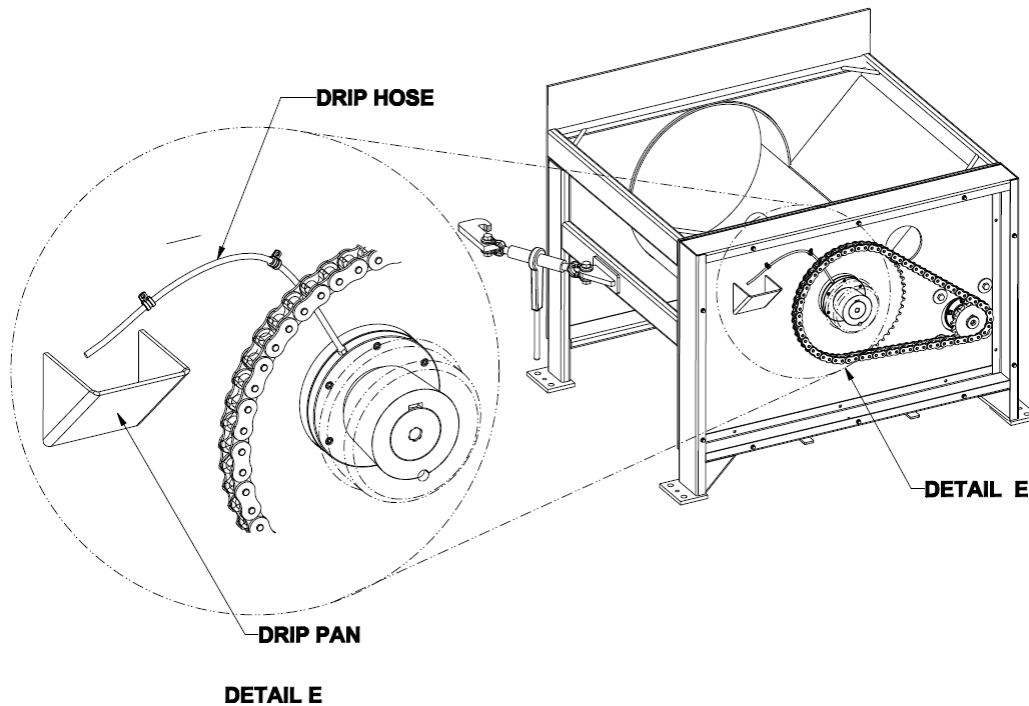

For units not equipped with Auto-Lube systems:

1. Clean the grease fitting. The fitting is located on the right-hand side just above the gearbox.

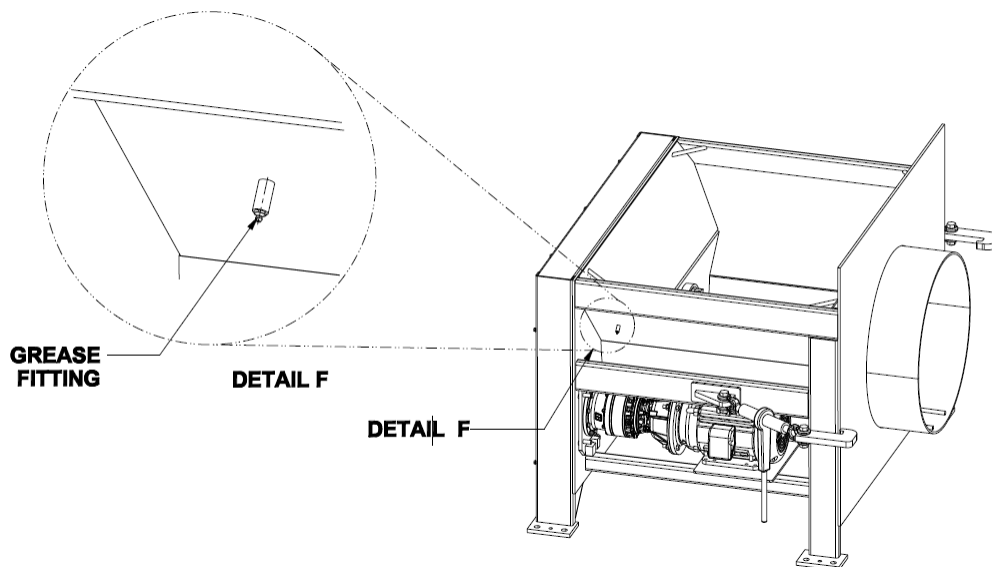

BEARING LUBRICATION (CONTINUED)

- The AST-440 has a grease fitting on both sides of the unit located just above the gearbox.

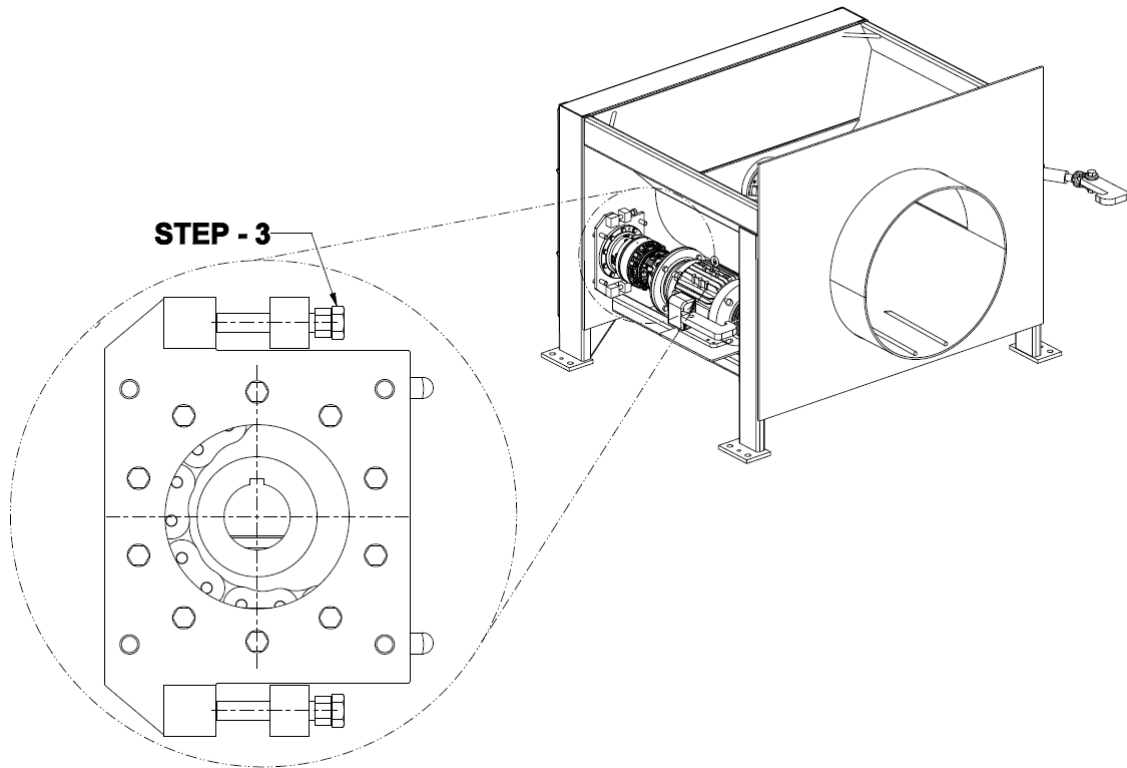

- Add grease to the grease fitting until fresh grease comes out of the drip hose.

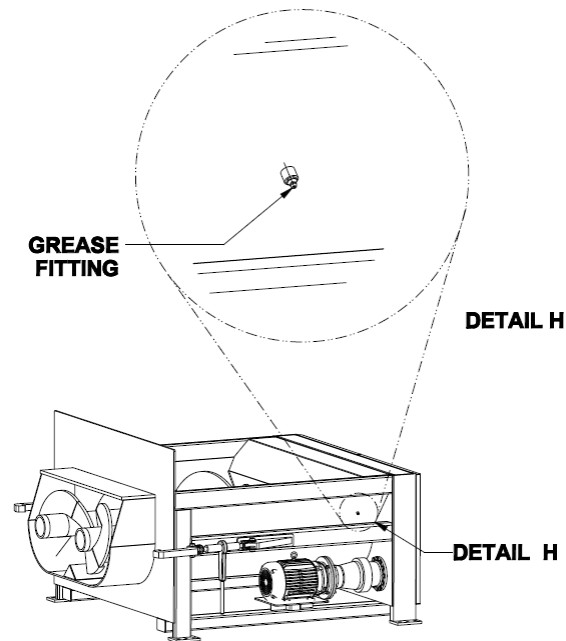

BEARING LUBRICATION (CONTINUED)

4. Clean off grease fitting.
5. Clean out excess grease from drip pan.

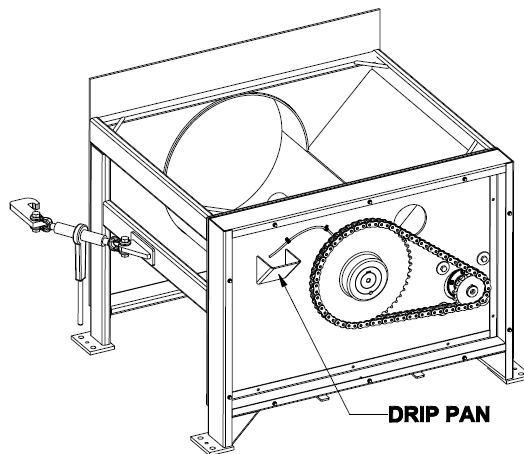

CHAIN TENSION AND ADJUSTMENT

WARNING

Never enter any part of the compactor until the unit has been Locked-out and Tagged-out.

WARNING

Add Warning Safety Alert text.

WARNING

Never service/adjust the chain until the unit has been locked-out and tagged out.

Chain/Sprocket Layout

1. To access the sprockets and chain, the rear cover must be removed.

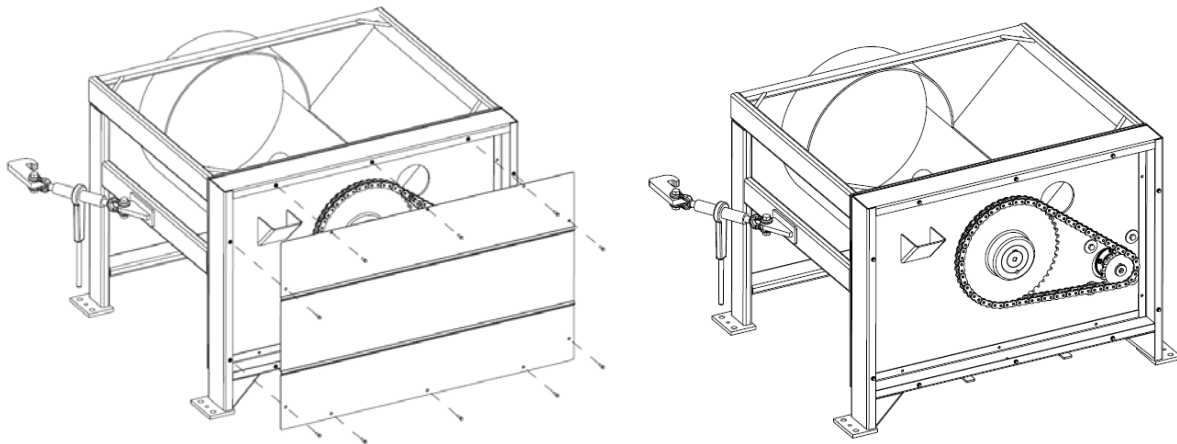

Note: The chain on the AST-440 model is non-adjustable.

Proper chain tension

The chain should have 1" – 1 1/2" of deflection, on the top side of the chain halfway between the sprockets, when finger pressure is added to the chain.

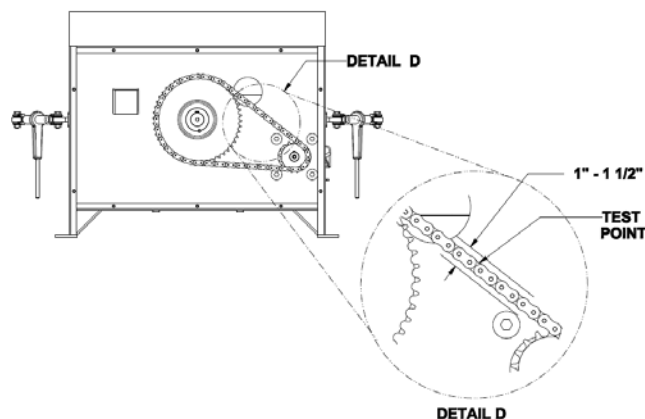

CHAIN TENSION AND ADJUSTMENT (CONTINUED)

How to adjust chain tension:

1. Loosen (4) gear box mounting plate bolts.

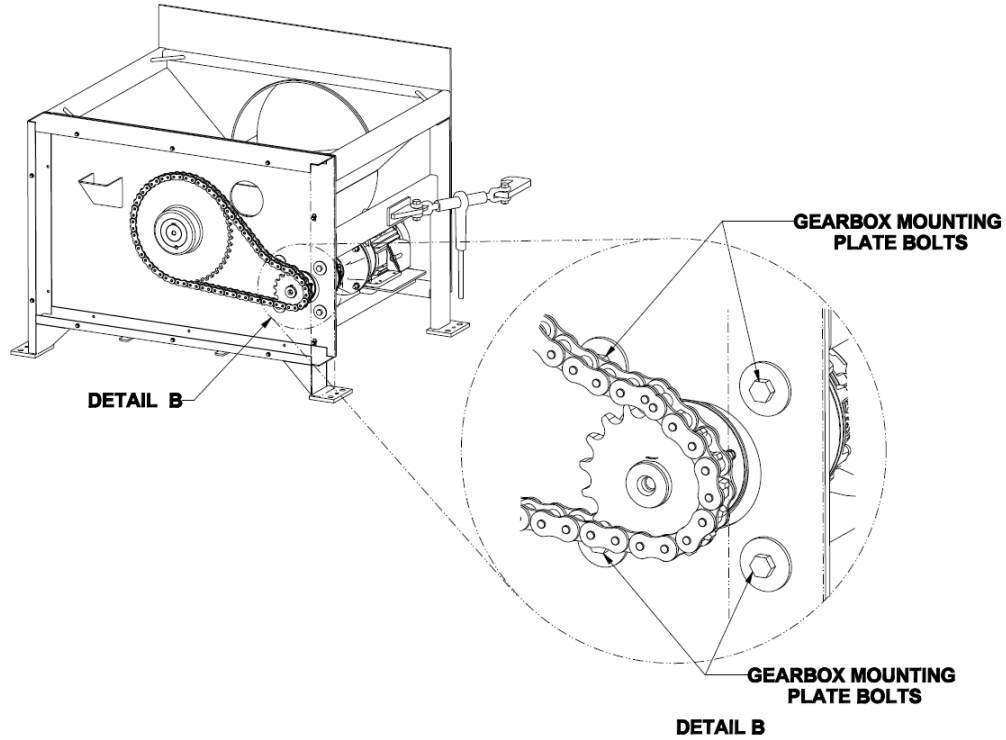

2. Loosen (2) jam nuts on the adjustment bolts.

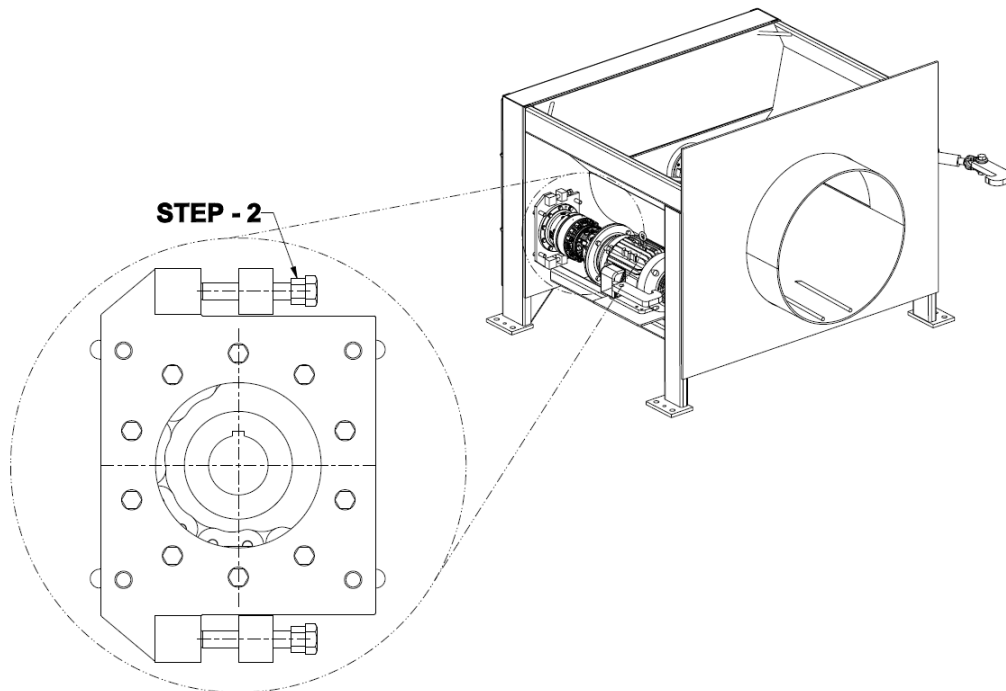

CHAIN TENSION AND ADJUSTMENT (CONTINUED)

3. Tighten (2) adjustment bolts until the proper tension is achieved.

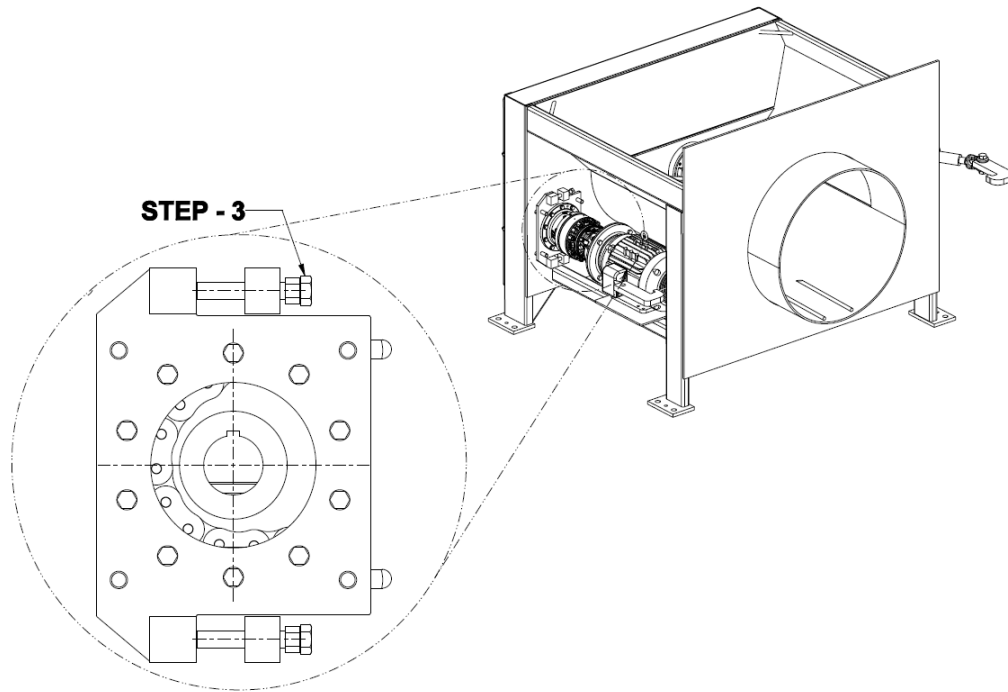

4. Tighten (2) jam nuts on the adjustment bolts.

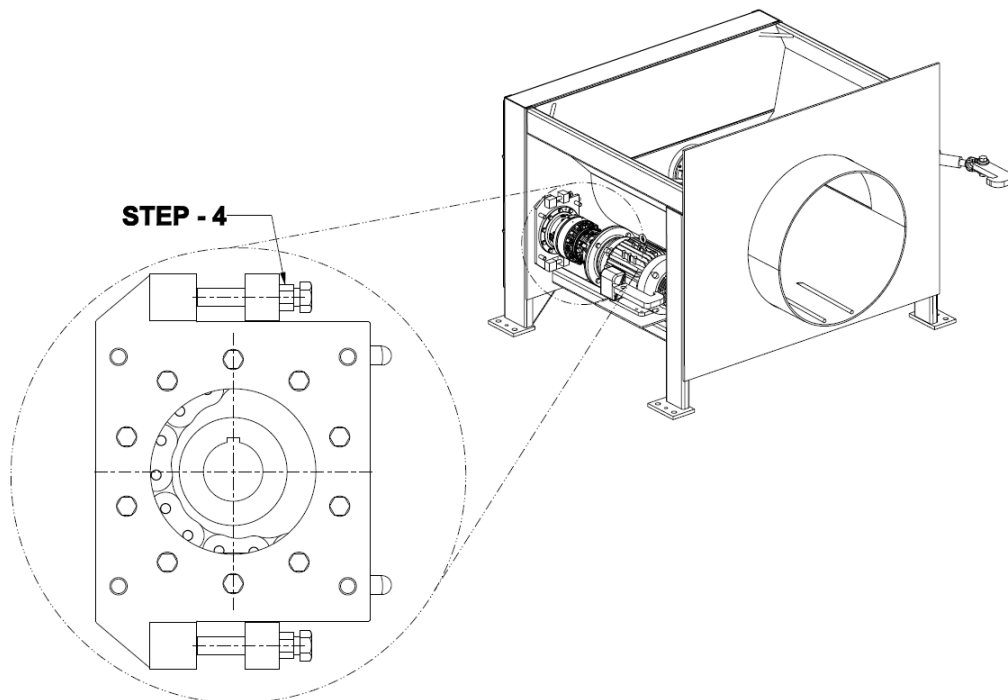

CHAIN TENSION AND ADJUSTMENT (CONTINUED)

5. Tighten (4) gearbox mounting plate bolts.

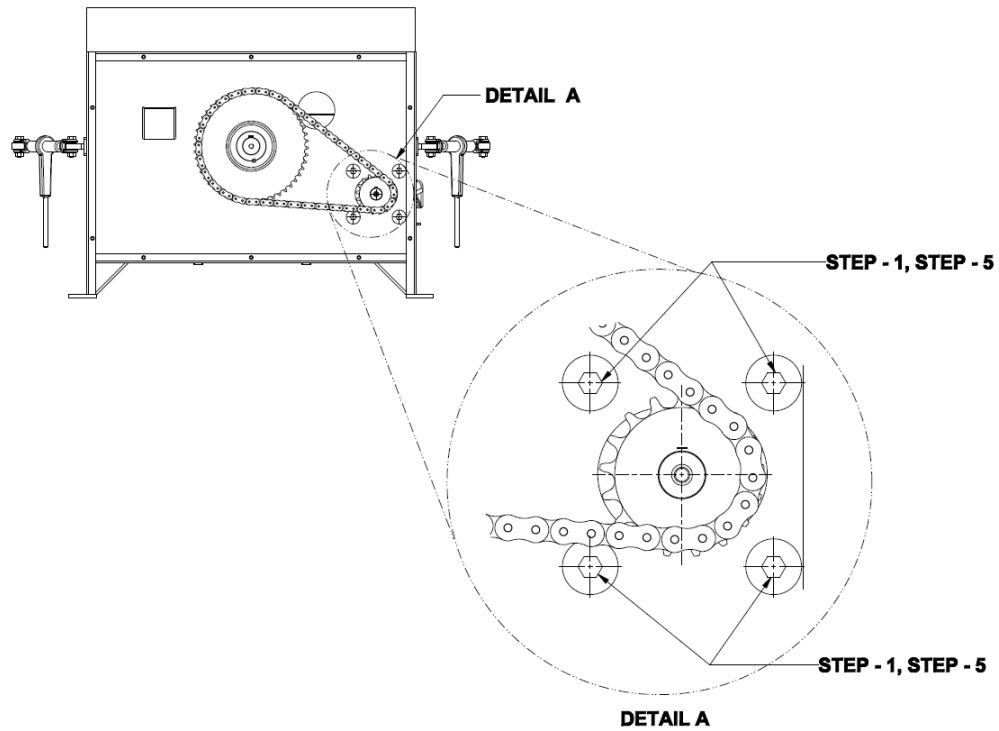

HARD SURFACE WELD

WARNING

Never enter any part of the compactor until the unit has been Locked-out and Tagged-out.

Inspection:

1. For stationary compactors - separate the compactor and container.
For self-contained compactors – dump compaction container.
2. Clean off the hard surface welded zone of the auger flights.

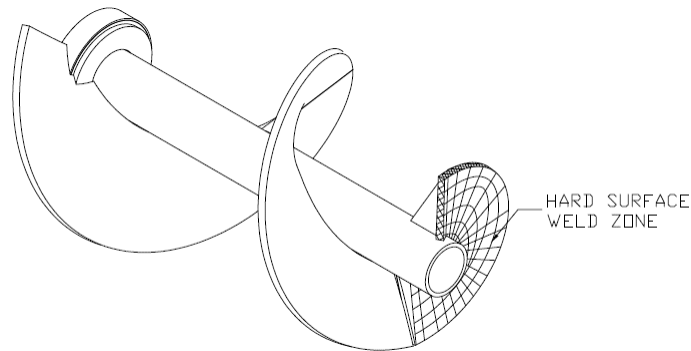

3. Measure the height of the hard surface weld perpendicular to the auger flight.

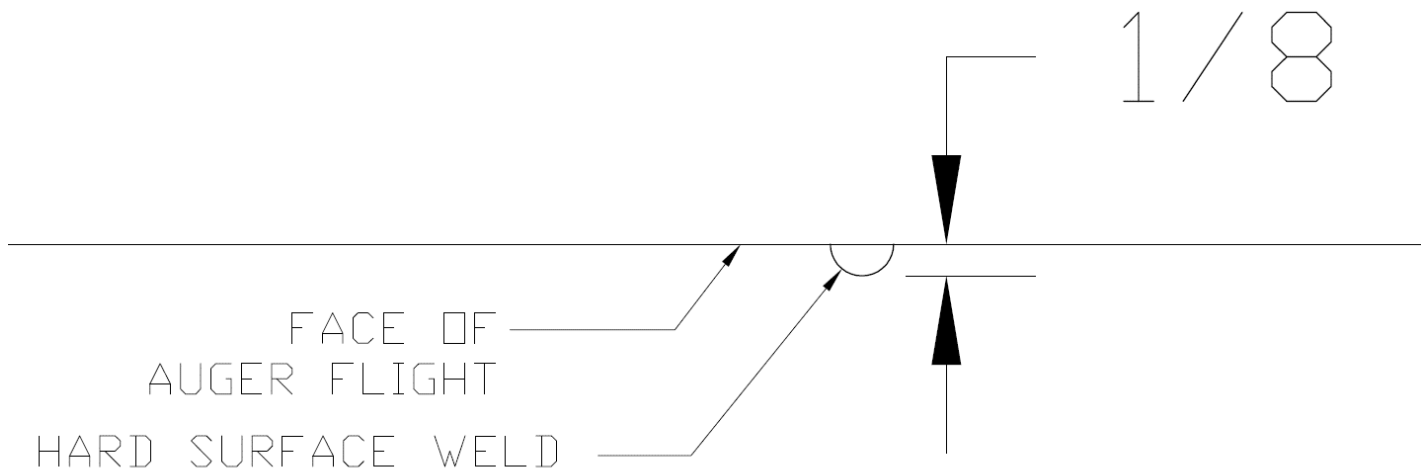

4. If the hard-surface weld height is less than 1/8", hard surface material needs to be re-applied.

Hard Surface Weld (Continued)

Hard surface weld wire specification and recommended settings:

GMAW-C (MIG)

- wire Weartech WT-1
- wire diameter .045"
- volts 26-28
- amps 240-260

or

- wire Lincore 60-0
- wire diameter .045"
- volts 25-27
- amps 190-210

SMAW (STICK)

- wire Weartech WT-1
- rod diameter .125"
- voltage dc+
- amps 115-135

Notes:

- Weld surface must be clean and free from all dirt, oil, and debris.
- Welding should be performed in a flat orientation.
- Material may crack during and after the welding process this is acceptable and expected.

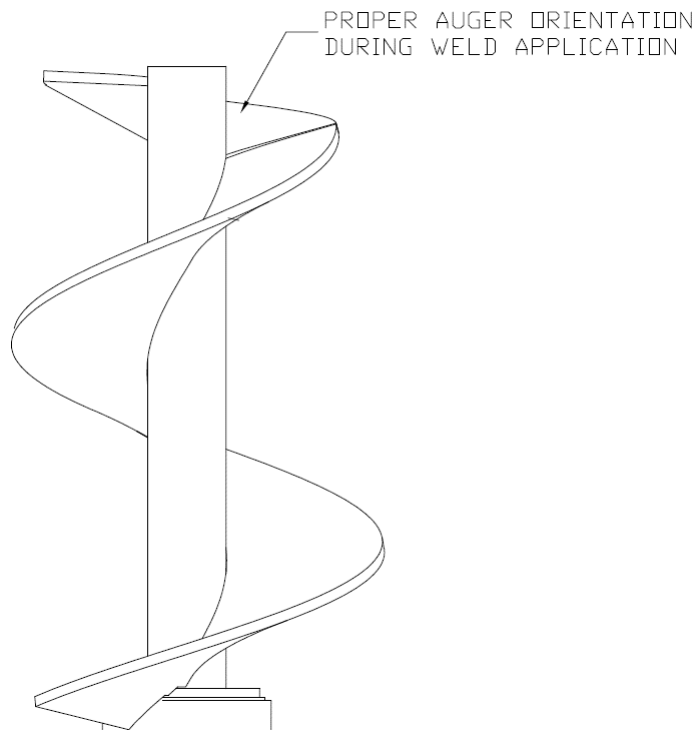

RamJet® Stationary Auger Compactor

Service

PRINCIPLES OF OPERATION

Standard Operation

Upon start up, a contact is made that energizes the motor starter, starting the electric motor and at the same time energizing T1 timer in the program. When T1 is energized, the auger will turn counterclockwise (forward) for the predetermined amount of time in T1. When T1 timer times out, auger will stop. If auger sees high enough amperage it will reverse causing T2 timer to energize and shift the auger clockwise (reverse). Auger will run in reverse for a predetermined time in T2. When T2 timer times out, the motor starter contact will shift back forward and timer T1 will go for it's predetermined time then shut down. If amperage is high every time auger is going forward then after the 6th time the auger will shut down.

AST-220 FUSES AND CIRCUIT BREAKERS

Three Phase					
MOTOR SIZE	VAC	FULL LOAD AMP	DUAL ELEMENT FUSE MAX. SIZE	CIRCUIT BREAKER MAX. SIZE	SERVICE DISCONNECT AMP.
20 HP	208	51.0	100	125	100
	230	48.0	90	125	100
	460	24.0	45	60	60
	575	19.1	35	50	60

AST-220 WIRE SIZES

Three Phase		THW Copper 75°C (165°F)		
MOTOR SIZE	VOLTAGE	LENGTH		
		TO 100'	TO 200'	TO 300'
20 HP	208	4	1	1/0
	230	4	2	1
	460	10	8	6
	575	10	10	8

RamJet® Stationary Auger Compactor

Service

AST-320 FUSES AND CIRCUIT BREAKERS

Three Phase					
MOTOR SIZE	VAC	FULL LOAD AMP	DUAL ELEMENT FUSE MAX. SIZE	CIRCUIT BREAKER MAX. SIZE	SERVICE DISCONNECT AMP.
20 HP	208	51.0	100	125	100
	230	48.0	90	125	100
	460	24.0	45	60	60
	575	19.1	35	50	60

AST-320 WIRE SIZES

Three Phase	THW Copper 75°C (165°F)			
MOTOR SIZE	VOLTAGE	LENGTH		
		TO 100'	TO 200'	TO 300'
20 HP	208	4	1	1/0
	230	4	2	1
	460	10	8	6
	575	10	10	8

RamJet® Stationary Auger Compactor

Service

AST-440 FUSES AND CIRCUIT BREAKERS

MOTOR SIZE	VAC	FULL LOAD AMP	DUAL ELEMENT FUSE MAX. SIZE	CIRCUIT BREAKER MAX. SIZE	SERVICE DISCONNECT AMP.
2 X 20 HP	208V	118	150	200	200
	230V	108	150	200	200
	460V	54	70	90	100
	575V	44	60	80	100

AST-440 WIRE SIZES

MOTOR SIZE	VOLTAGE	LENGTH		
		TO 100'	TO 200'	TO 300'
2 X 20 HP	208V	1/0	3/0	4/0
	230V	1/0	2/0	4/0
	460V	4	4	2
	575V	6	6	4

RamJet® Stationary Auger Compactor

Service

PLC MAINTENANCE - LAYOUT & DESCRIPTION

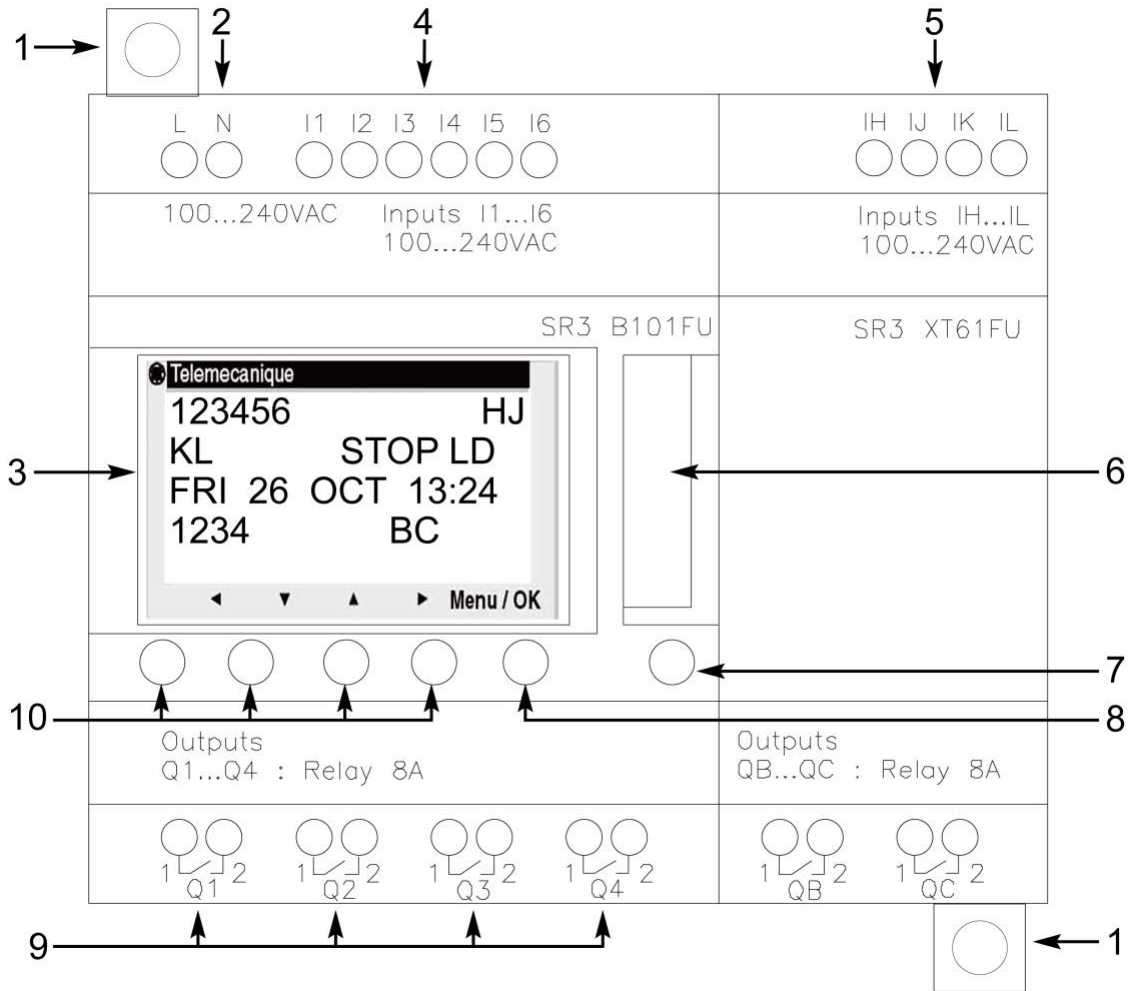

REFERENCE	DESCRIPTION
1	RETRACTABLE MOUNTING FEET.
2	SCREW TERMINAL BLOCK FOR THE POWER SUPPLY.
3	LCD, 4 LINES, 18 CHARACTERS
4	SCREW TERMINAL BLOCK FOR INPUTS
5	SCREW TERMINAL BLOCK FOR 0-10 VOLT ANALOG INPUTS USABLE IN DISCRETE MODE ON SOME MODELS
6	CONNECTOR FOR BACKUP MEMORY OR PC CONNECTION CABLE
7	SHIFT KEY
8	SELECTION AND VALIDATION KEY (MENU / OK)
9	RELAY OUTPUT SCREW TERMINAL BLOCK
10	ARROW KEYS OR AFTER FIRST CONFIGURING THEM, Z PUSHBUTTONS

RamJet® Stationary Auger Compactor

Service

PLC MAINTENANCE - FORWARD/REVERSE TIMER

STEPS	DIRECTIONS
1	PRESS MENU/OK BUTTON
2	PRESS ARROW DOWN BUTTON TO SELECT PARAMETER (SHOULD BE FLASHING)
3	PRESS MENU/OK BUTTON
4	PRESS ARROW UP BUTTON UNTIL TT1 = FORWARD TIMER (FLASHING)
5	PRESS ARROW LEFT BUTTON UNTIL TIME SETTING (FLASHING)
6	PRESS ARROW UP OR ARROW DOWN TO ADJUST TIME*
7	PRESS MENU/OK BUTTON
8	PRESS MENU/OK BUTTON TO CONFIRM CHANGES
9	PRESS ARROW LEFT BUTTON TO RETURN TO TT1 = FORWARD TIMER (FLASHING)
10	PRESS MENU/OK BUTTON TO RETURN TO NORMAL OPERATION
*NOTE: THE TIMER FOR EACH OPERATION WILL BE LISTED ON THE SCHEMATIC.	

RamJet[®] Stationary Auger Compactor

Service

ELECTRICAL SCHEMATIC

Refer to the electrical schematic shipped with your compactor or contact Marathon Equipment Company's Technical Service Department at 877-258-1105. Be sure to have compactor serial number ready when contacting service.

RamJet[®] Stationary Auger Compactor

Service

TROUBLESHOOTING CHART

TROUBLESHOOTING CHART		
PROBLEM	CAUSE	SOLUTION
UNIT WILL NOT START	1. No electrical power to unit	1a. Turn on main disconnect. 1b. Replace fuse or reset breakers.
	2. No electrical power to control circuit	2a. Check primary and secondary sides of transformer. 2b. Check for correct voltage. Check control fuses. 2c. Check stop button. 2d. Check start button to be sure contact closes when depressed.
	3. No electrical power to motor	3a. Check heater resets
UNIT WILL NOT CONTINUE RUNNING WHEN START BUTTON IS RELEASED	1. Motor starter is inoperative.	1a. Check motor starter coil & wiring.
	2. Motor starter auxiliary contacts are inoperative	2a. Check motor starter contacts and wiring
UNIT WILL NOT REVERSE	1. Reverse Motor Starter not energized	1a. Check coil Motor Starter
ERRATIC OPERATION	1. Low voltage	1a. Check primary & secondary sides of transformer for correct voltage.
OVERLOADS TRIP FREQUENTLY	1. Incorrect voltage	1a. Check for correct voltage
	2. Excessive load on motor	2a. Check current transducer and transducer setting. 2b. Check chain and gear box alignment.
	3. Possible problem with motor	3a. Check motor windings for shorted or open windings 3b. Check motor bearings and lubrication
	4. Improper overload setting	4a. Check overload section for correct setting. Adjust as needed 4b. Check overload for correct size
	5. Loose connections	5a. Check all connections on motor starter, overload section, and in motor junction box for loose connections. Tighten as needed
	Note: Excessive overload tripping and/or motor or coil failures may occur if voltage surges or voltage drops are frequent in your area. This circumstance can be remedied by the installation of phase protectors which drop power to the motor if surges are present.	

INTENTIONALLY LEFT BLANK

SECTION 5

REPLACEMENT PARTS

CONTACT INFORMATION



Technical Service and Warranty:

877-258-1105

Parts:

800-528-5308

For parts visit our e-commerce market place at www.mecomerchant.com.

If you do not have a user name and password, contact our Parts Department and they will assist with your registration.

Normal Business Hours:

Monday-Friday 8:00am - 5:00pm

(Central Standard Time)

RamJet® Stationary Auger Compactor Replacement Parts

TYPICAL PANEL BOX CONFIGURATION

The diagram below represents a typical panel box configuration for the self-contained compactors. The panel box on your compactor may differ depending on the model and/or optional equipment/controls. Refer to the chart below to identify components. To order replacement parts, please call our Parts Department at 800-528-5308.

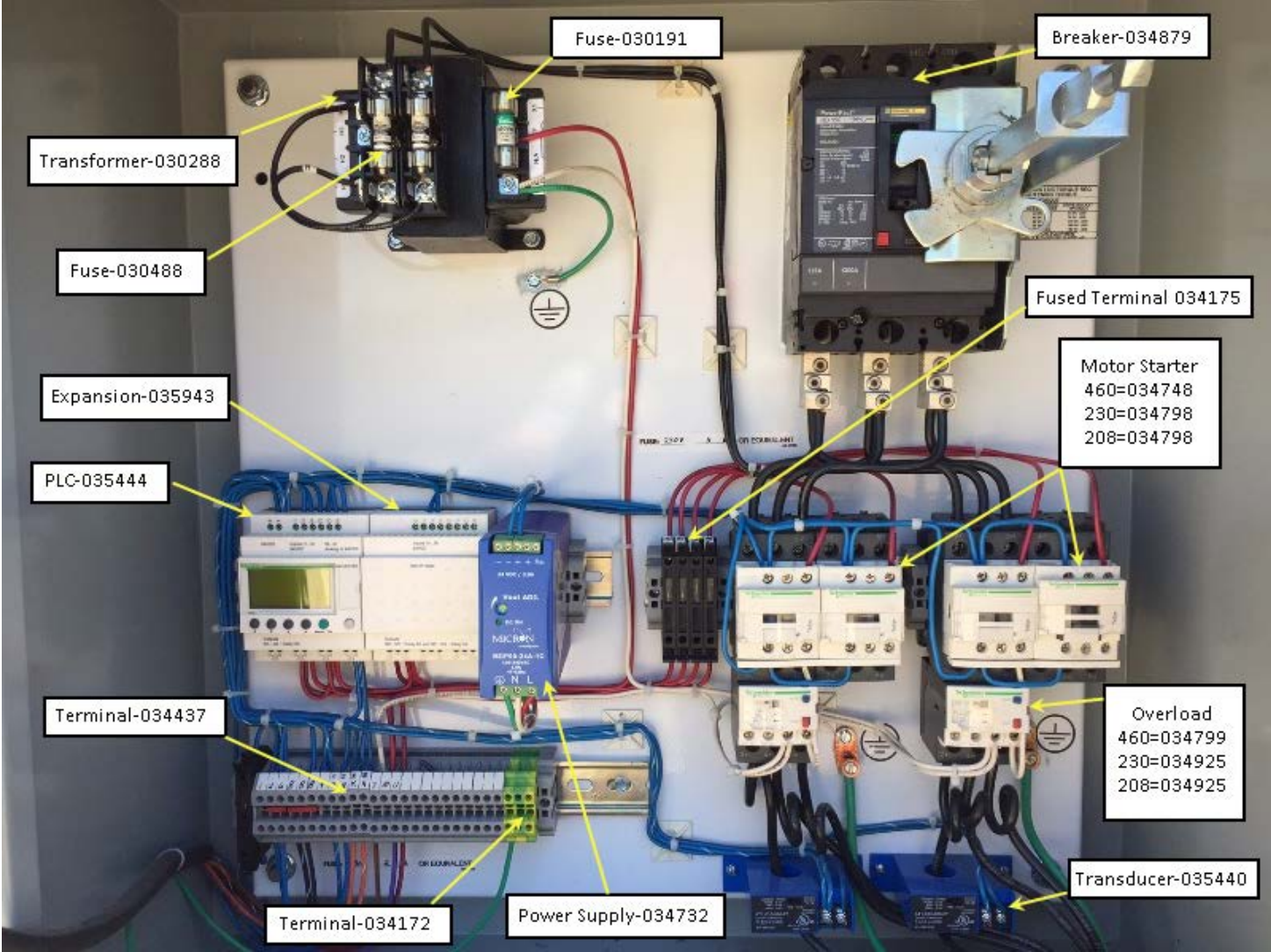

RamJet® Stationary Auger Compactor

Replacement Parts

DECAL PARTS LIST

⚠ WARNING

When your compactor leaves the factory, several WARNING DECALS are installed for your protection. These labels are subject to wear and abuse due to the nature of operation. The FOLLOWING DECALS MUST BE MAINTAINED. Additional decals may be purchased through your distributor or from Marathon Equipment Company by calling the parts department at 800-528-5308.

Note: When ordering replacement decals, use the chart below with the drawing on the next page or look for the part number in the lower right hand corner of the decal.

PART#	DESCRIPTION	QTY
06-0002	RAM-JET	3
06-0038	WARNING: DO NOT REMOVE ACCESS COVER	1
06-0039	DANGER: DO NOT ENTER	3
06-0121	NOTICE: FEDERAL REGULATION	2
06-0249	DANGER: HAZARDOUS VOLTAGE	1
06-1839	AMERICAN FLAG	3
06-3123	DANGER: CONFINED SPACE	3
06-0097	COMPACTOR SERIAL PLATE	1
06-3976	WARNING: ARC FLASH HAZARD	
06-3977	WARNING: DO NOT OPERATE	2
06-3978	DANGER: DO NOT OVERRIDE	2
06-0133	WARNING: KEEP OFF	2
06-2751	"MARATHON COMP & RECYCLING" DECAL	2
06-3044	DANGER VOLTS	
06-0040	DANGER: CRUSHING HAZARD ... KEEP OUT ****	
06-3333	NOTICE: IN THE EVENT OF FIRE ****	
06-0052	DANGER: GATE MUST BE CLOSED ****	
*** ONLY ON UNITS WITH SIDE MOUNT PPK **** ONLY ON OPTIONAL LOADING CONFIGURATIONS. SEE DECAL PLACEMENT FOR OPTIONAL LOADING CONFIGURATIONS  52.		

RamJet® Stationary Auger Compactor Replacement Parts

DECAL PLACEMENT

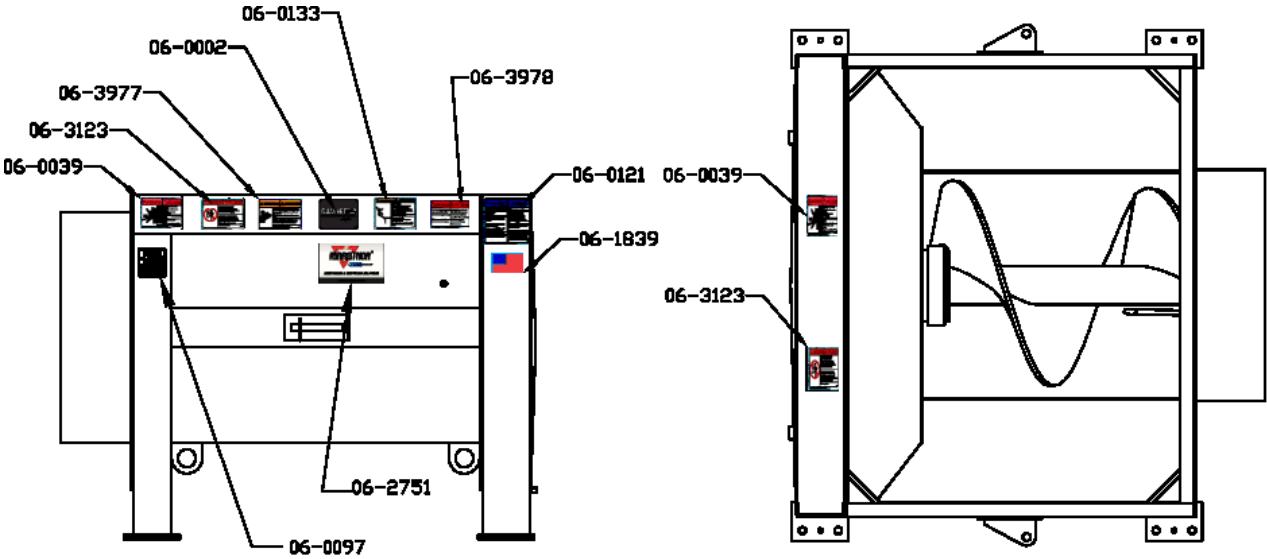

LEFT SIDE VIEW

TOP VIEW

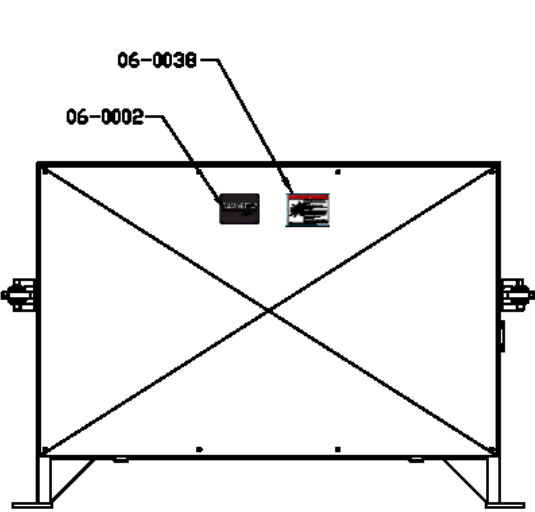

REAR VIEW

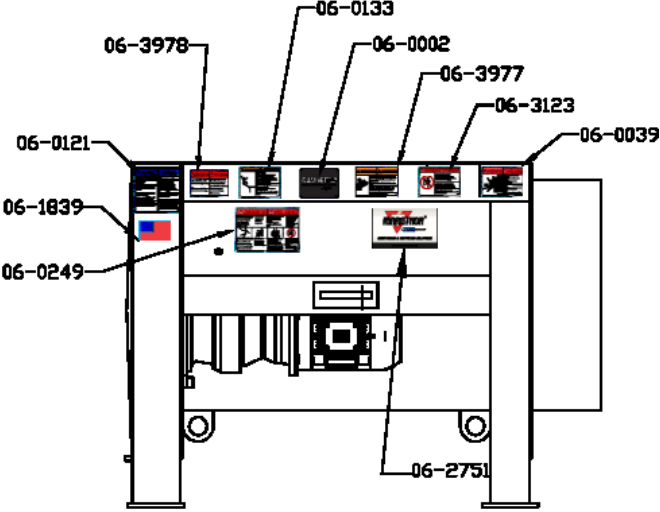

RIGHT SIDE VIEW

RamJet® Stationary Auger Compactor Replacement Parts

DECAL PLACEMENT FOR OPTIONAL LOADING CONFIGURATIONS

In addition to the standard decal placement, the following decals shown below need to be maintained on any optional loading configurations installed with your horizontal compactor. Match the reference numbers with the decals listed on the **Decals** chart. Since quantities vary by installation, it is best to record the quantity of each of these decals at the time of installation for future reference.

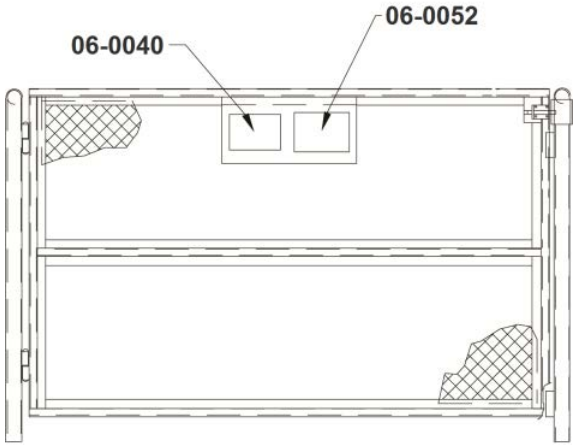

ACCESS GATE

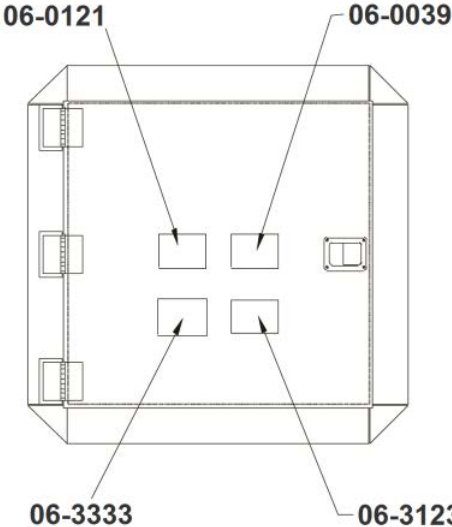

**SECURITY
DOOR**

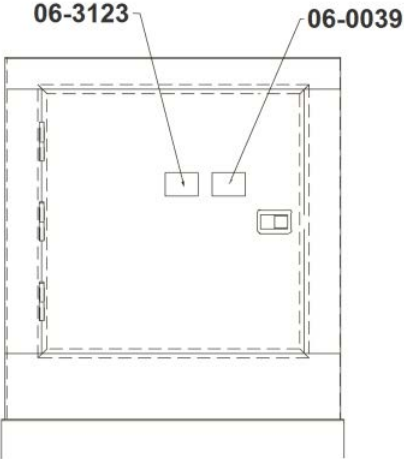

REAR FEED DOGHOUSE

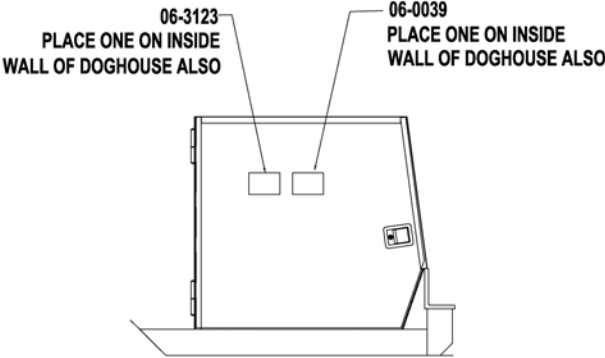

SIDE FEED DOGHOUSE

RamJet® Stationary Auger Compactor

Replacement Parts

DECAL PLACEMENT FOR OPTIONAL LOADING CONFIGURATIONS (CONTINUED)

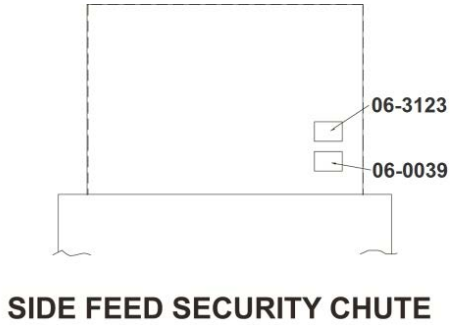

SIDE FEED SECURITY CHUTE

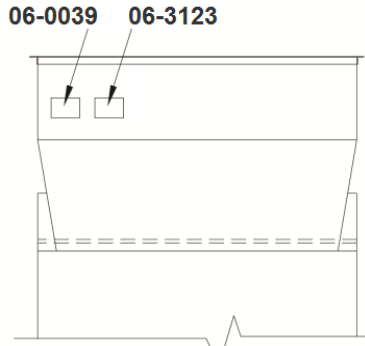

REAR VIEW

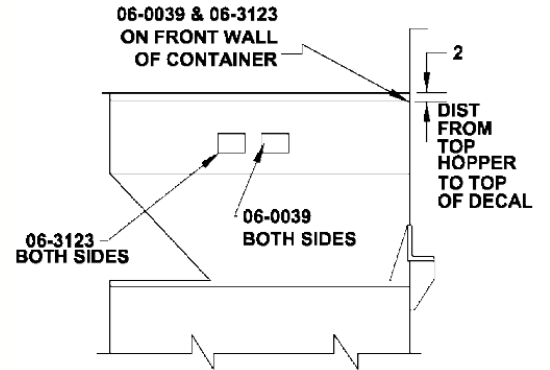

SIDE VIEW

4 SIDED HOPPER

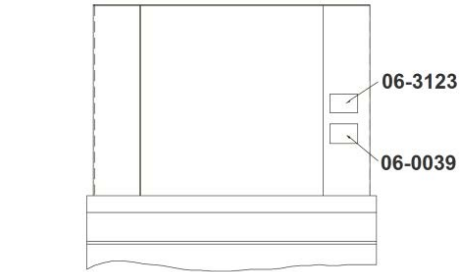

REAR FEED SECURITY CHUTE

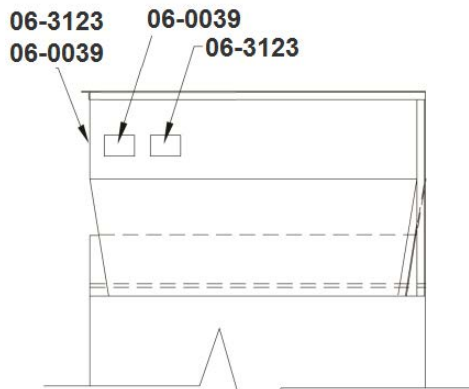

REAR VIEW

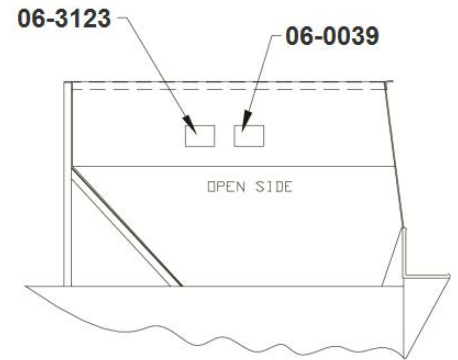

SIDE VIEW

3 SIDED HOPPER

RamJet® Stationary Auger Compactor Replacement Parts

DECAL IMAGES

06-0038



DO NOT PAINT OVER THIS LABEL. REPLACE IF DAMAGED OR LOST. NO PINTAR ENCIMA DE ESTA ETIQUETA. REEMPLAZARLA SI SE DAÑA O SE PIERDE.

06-0039



06-3044



06-0052



06-3978



DO NOT PAINT OVER THIS LABEL. REPLACE IF DAMAGED OR LOST. NO PINTAR ENCIMA DE ESTA ETIQUETA. REEMPLAZARLA SI SE DAÑA O SE PIERDE.

06-0040



DO NOT PAINT OVER THIS LABEL. REPLACE IF DAMAGED OR LOST. NO PINTAR ENCIMA DE ESTA ETIQUETA. REEMPLAZARLA SI SE DAÑA O SE PIERDE.

06-0249



06-3123



DO NOT PAINT OVER THIS LABEL. REPLACE IF DAMAGED OR LOST. NO PINTAR ENCIMA DE ESTA ETIQUETA. REEMPLAZARLA SI SE DAÑA O SE PIERDE.

06-0133



06-3977



06-3333

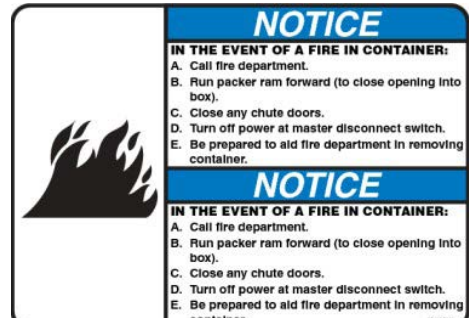

06-1839



06-0002

06-2751

06-0121

RamJet® Stationary Auger Compactor Replacement Parts

DECAL IMAGES



NOTICE	AVISO
<ul style="list-style-type: none"> Federal law prohibits operation of equipment by persons under 18 years of age. Machine may only be loaded and operated by persons who have been authorized and properly trained. U.S. Department of Labor age restrictions apply. The key in the "ON-OFF" switch must be turned to the "OFF" position and removed when this equipment is NOT in operation. The key is to remain in the custody of persons 18 years and older. 	<ul style="list-style-type: none"> Las leyes federales prohíben que personas menores de 18 años de edad operen los equipos. Las personas que han sido autorizadas y debidamente entrenadas son las únicas que pueden cargar y operar la máquina. Sujeta a las restricciones de edad del Departamento del Trabajo de Estados Unidos. La llave en el interruptor "ON-OFF" (ENCENDIDO/APAGADO) se debe girar a la posición "OFF" (APAGADO) y retirarla cuando este equipo no está en funcionamiento. La llave debe permanecer bajo el cuidado de personas mayores de 18 años.

06-0413

06-0097

⚠ WARNING	
	<p>CRUSH HAZARD!</p> <p>When changing containers repositioning transfer vehic turn key switch to off positi and remove key. Failure to c so could result in death or serious injury.</p>
⚠ ADVERTENCIA	
	<p>¡RIESGO DE APLASTAMIENTOS!</p> <p>Al cambiar los recipientes c cambiar la posición de los vehículos de transferencia, girar la llave a la posición d apagado y sacarla. Si no se cumple con esta disposición se puede causar la muerte o lesiones graves.</p>

<p>A DOVER COMPANY</p> <p>VERNON, AL - PHOENIX, AZ 1-800-633-8974</p>	
COMPACTORS	
MODEL NO. _____	
SERIAL NO. _____	
DATE OF MFG. _____	PLANT # _____
FORCE RATING (MAX., LBS.) _____	
<p>MANUFACTURED IN ACCORDANCE WITH ANSI STANDARDS IN EFFECT AT DATE OF MANUFACTURE</p> <p>MADE IN USA 06-0364</p>	

06-3976

⚠ WARNING		⚠ ADVERTENCIA	
	<p>Potential shock and arc flash hazards Follow all requirements in NFPA 70 E for safe work practices and for personal protective equipment. Failure to comply could result in death or serious injury. Posibles riesgos de descargas y destellos de arco.</p>		<p>Acate todos los requisitos de la norma NFPA 70 E para prácticas de trabajos seguras y equipo de protección individual. El incumplimiento de esta norma podría resultar en la muerte o lesiones graves.</p>

DO NOT PAINT OVER THIS LABEL. REPLACE IF DAMAGED OR LOST.
NO PINTE ENCIMA DE ESTA ETIQUETA. REEMPLÁCELA SI SE DAÑA O SE PIERDE.

RamJet® Stationary Auger Compactor Replacement Parts

SPARE PARTS LISTS

AUGER MOTORS				
MOTOR	460V	575V	230/460V	208V
15kw - 20 hp	036875	036902	036922	037273
11kw - 15 hp	036874	036962	036907	N/A
7.5kw - 10 hp	N/A	037046	037045	N/A

FIELD KIT PARTS LIST		
REF	PART #	PART DESCRIPTION
A	456242	MAIN DRIVE SHAFT
B	35-5235	DRIVE SHAFT KEY
C	06-4107	RING SEAL
D	06-4135	SEAL-CR49998
E	06-4136	SEAL-CR50070
F	06-4131	BEARING 33122
G	06-4132	BEARING 33220
H	06-4133	NUT LOCK TAB MB20
I	06-4134	LOCK NUT KMFE20
J	06-4104	SEAL-H606-NB1
K	06-4115	SPROCKET-50T-120
L	06-4115	TAPER LOCK BUSHING
M	06-4114	SPROCKET-17T-120
N	06-4113	CHAIN HT-120H X 11'
P	05-3760	CAP SCREWS
Q	34-9331	FRONT BEARING COVER
R	06-4301	O-RING
S	34-9332	REAR BEARING COVER
T	06-4099	AUGER (ASC 06-4100)
U	34-9337	1"-8 ALL THREAD
V	05-0069	FLAT WASHER
W	05-0560	LOCK WASHER
X	05-4120	NUT
Y	06-4111	GEAR BOX (SC 06-4112)
Z		SEE TABLE

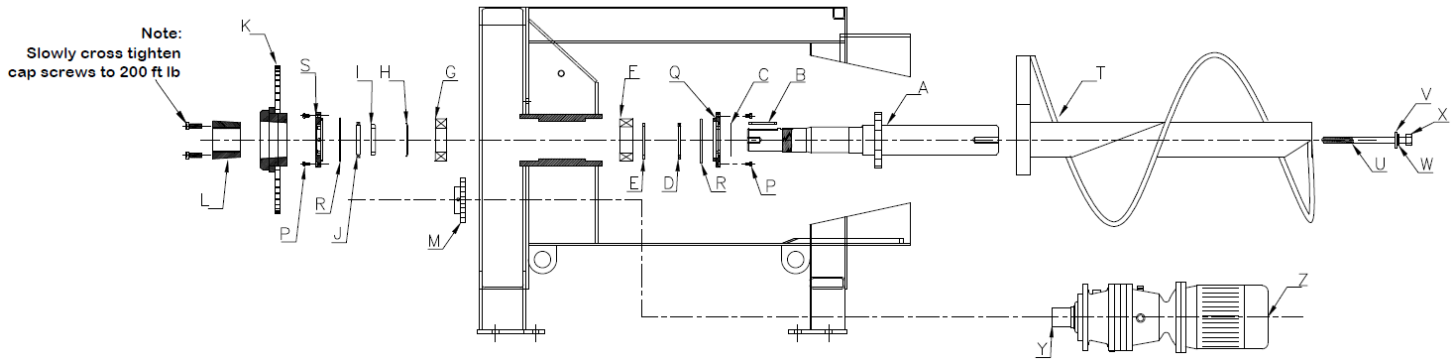
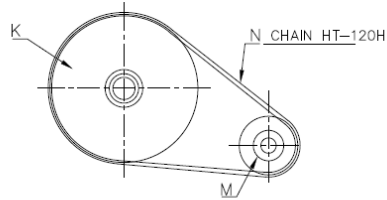

RamJet® Stationary Auger Compactor

Replacement Parts

SPARE PARTS LISTS (CONTINUED)

AST-440 DRIVETRAIN PARTS LIST		
PART NUMBER	PART DESCRIPTION	
A	35-3596	AUGER SCREW CAP
B	05-4120	NUT
C	05-0069	WASHER
D	35-3595	1"-8 ALL THREAD ROD
E	06-4250	RIGHT HAND SCREW
	06-4251	LEFT HAND SCREW
F	458176	MAIN DRIVE SHAFT
G	35-3584	DRIVE SHAFT KEY
H	05-4134	CAP SCREWS
I	35-3109	FRONT BEARING COVER
J	06-4282	O-RING
K	06-4257	SEAL
L	06-4262	O-RING
M	06-4255	BEARING 32230
N	06-4256	BEARING 32228
O	06-4260	LOCK WASHER MB 28
P	06-4261	LOCK NUT KM 28
Q	06-4258	SEAL
R	35-3110	REAR BEARING COVER
S	35-6341	PINNING EAR
T	05-5031	RATCHET
U	32-9403	RATCHET CLAW

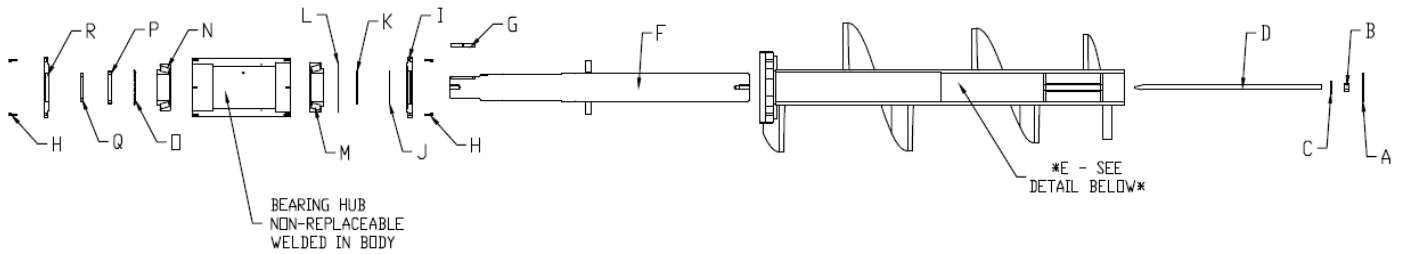
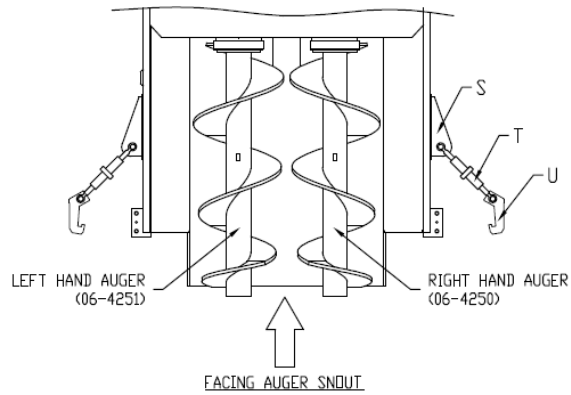

RamJet® Stationary Auger Compactor

Replacement Parts

SPARE PARTS LISTS (CONTINUED)

AST-320 SPARE PARTS LIST		
	PART NUMBER	PART DESCRIPTION
A	06-4259	AUGER CHAIN
B	06-4253	LARGE SPROCKET
C	06-4252	SMALL SPROCKET
D	06-4432	CHAIN MASTER LINK
E	03-7273	208V MOTOR
	03-6922	230/460V MOTOR
	03-6902	575V MOTOR
F	06-4254	GEARBOX
G	05-5628	BOLT
H	05-0561	WASHER
I	05-2301	WASHER
J	05-0547	BOLT
K	05-2533	WASHER
L	05-2301	NUT
M	05-0273	BOLT
N	05-0018	NUT

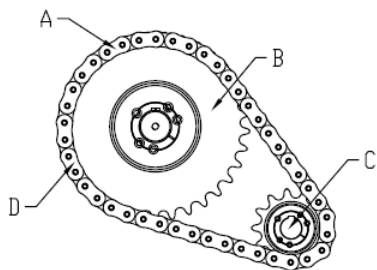
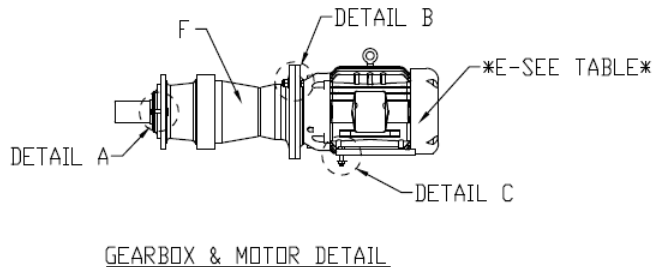
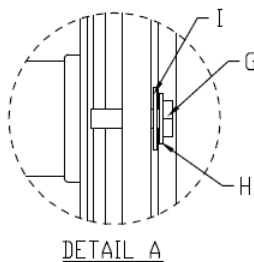
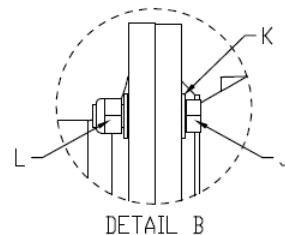
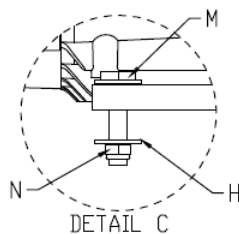

SPROCKET DETAIL

RamJet® Stationary Auger Compactor

Replacement Parts

SPARE PARTS LISTS (CONTINUED)

AST-440 SPARE PARTS LIST		
	PART NUMBER	PART DESCRIPTION
A	06-4259	AUGER CHAIN
B	06-4253	LARGE SPROCKET
C	06-4252	SMALL SPROCKET
D	06-4432	CHAIN MASTER LINK
E	03-7273	208V MOTOR
	03-6922	230/460V MOTOR
	03-6902	575V MOTOR
F	06-4254	GEARBOX
G	05-0273	BOLT
H	05-0052	WASHER
I	05-0018	NUT
J	05-0547	BOLT
K	05-2533	WASHER
L	05-2301	NUT
M	05-0273	BOLT

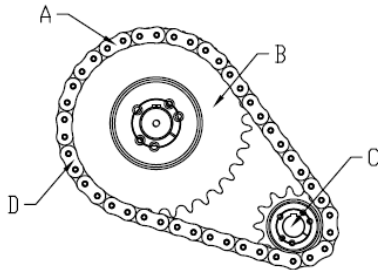
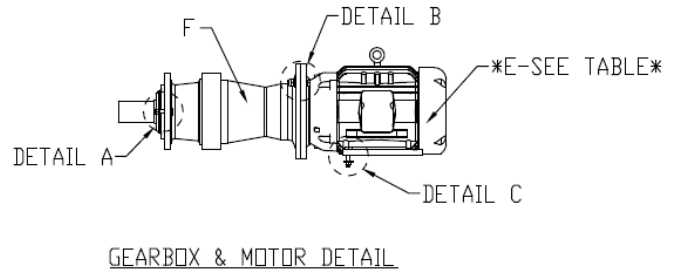
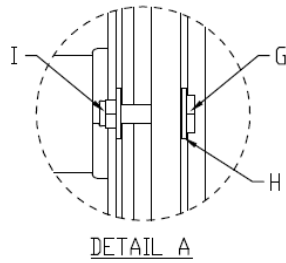
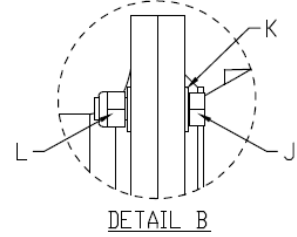
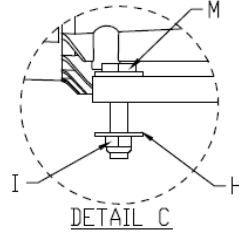

INTENTIONALLY LEFT BLANK

RamJet® Stationary Auger Compactor

INDEX

A

anchoring 15

C

chute-fed installation 16
concrete pad requirements 15
contact information 14, 20, 26, 48
container guides 16

D

decals care 9
decals images 54
decals placement 51
decals placement for optional loading configuration 52
decals parts list 50
Distance of nozzle to decal: 15" minimum 9
Do not allow fuels to stay in contact with the decal for an extended period of time. Remove the fuel contamination as quickly as possible 9
Do not use a mechanical brush while washing the decals. 9
Do not use carnauba-based wax over the decals 9
Do not use sharp angles to clean the decals – this can lift the decals from the unit. 9
dock installation 16

E

electric schematic 44
electrical installation 17
electrical symbols 11

F

Following these instructions helps the decals adhere longer. 9
forward/reverse timer 43
Fuses, Circuit Breaker, & Wire Size Charts 39

G

General Instructions 9
grease lubrication recommendation 8
grounding instructions 17
guards and access covers 8

I

If these methods do not work on a problem area, call a Marathon Equipment Company Dealer or Marathon Equipment Company Customer Support. 9
introduction 4

It is important that the decals are properly cleaned to make sure that they are readable and do not come off the unit. Use the following steps to clean the decals. 9

L

Length of time: not more than 30 sec. 9
Let the unit air-dry or dry with a micro-fiber cloth 9
lock-out/tag-out instructions 6

M

maintenance schedule form 28

N

NEVER use a "turbo pressure nozzle". 9

O

operating instructions 22
operating instructions for models with photoelectric cycle controls 23
optional controls 24

P

periodic maintenance 27
plc maintenance layout & description 42
preface 5
pre-operation instructions 21
Pressure Washer Precautions 9
Pressure washing can cause damage to decals. It can cause the edges of the decals to lift and peel the decal away from the unit. Over time, the decal can fade, crack or chip away. 9
principles of operation 39

R

recommended oils for gearbox 8
regenerative operation 39
remote power pack installation 17
Remove Difficult Debris 9
replacement parts 47
Rinse with clean water 9

RamJet® Stationary Auger Compactor

INDEX

S

- safety symbols and definitions 5
- service/parts assistance 8
- spare parts lists 56
- Spot clean the decal with Isopropyl Alcohol and a micro-fiber cloth (rag) 9
- Spray angle: 65° from vehicle' s body 9
- Spray nozzle opening: 40° wide pattern 9
- standard control panel 22
- standard operation 39
- steel installation procedures 16

T

- troubleshooting chart 45
- typical panel box configuration 49

U

Use pressure washing only when other cleaning methods are not effective. If you use a pressure washer, use the following precautions. 9

W

- warning decals on the unit 9
- Wash the decals with a blend of mild car wash detergent and clean water 9
- Water pressure: less than or equal to 800 psi 9
- When normal cleaning procedures do not remove difficult debris from the decals, try the following: 9



www.marathonequipment.com

Customer Care:
800-633-8974

Parts Central:
800-528-5308
www.mecomerchant.com

Technical Service and Warranty:
877-258-1105

Customer Support:

Marathon Equipment Company
P.O. Box 1798
Vernon, AL 35592-1798